

DOMEKT
C6M AUTOMATION

INSTALLATION MANUAL

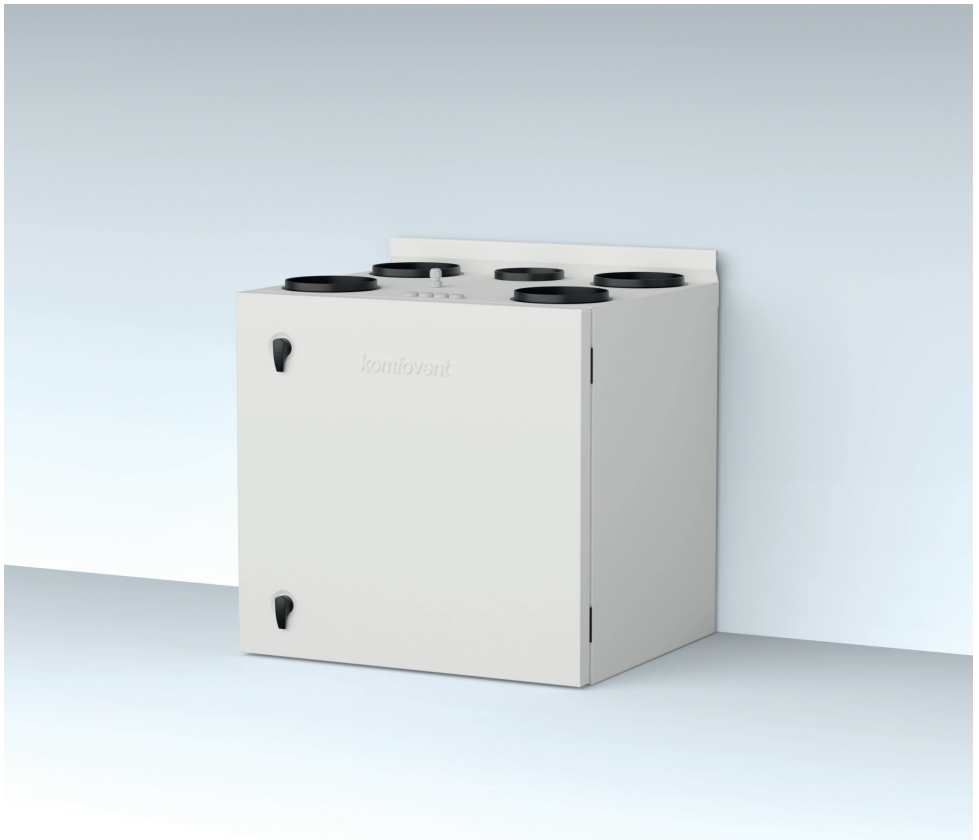

CONTENT

1. INTRODUCTION	4
1.1. Safety requirements	4
1.2. Design of the units	5
1.3. Components	7
1.3.1. Horizontal units	7
1.3.2. Vertical units	9
1.3.3. Flat units	12
2. UNIT TRANSPORTATION AND STORAGE	15
3. MECHANICAL INSTALLATION	16
3.1. List of parts in the package	16
3.2. Installation site requirements	16
3.2.1. Maintenance area	17
3.2.2. Humidity in the installation room	18
3.3. Unit dimensions	20
3.3.1. Vertical units	20
3.3.2. Horizontal units	21
3.3.3. Flat units	22
3.4. Hanging of the units	23
3.4.1. Types and dimensions of suspension brackets	24
3.5. Duct system installation	26
3.6. Connection of external heating/cooling units	29
3.6.1. Thermostat function	30
3.7. Connection of condensate drain	30
4. ELECTRICAL INSTALLATION	31
4.1. Electrical input requirements	32
4.2. Connecting electrical components	32
4.3. Control panel installation	36
4.4. Connecting the unit to an internal computer network or the Internet	38
5. STARTING AND CHECKING THE UNIT	40
5.1. Control panel C6.1	42
5.2. Control panel C6.2	43
5.3. Start-up of the unit using a computer	44
5.4. Quick check	46

1. INTRODUCTION

This manual is intended for qualified technicians installing the DOMEKT air handling unit. Qualified professionals are persons with sufficient professional experience and knowledge of ventilation systems, their installation, knowledge of electrical safety requirements and ability to work without risk to themselves or others.

1.1. Safety requirements

To avoid misunderstandings, read this manual carefully before installing the unit.

Air handling unit may only be installed by a qualified technician in accordance with the instructions given in this manual and in accordance with applicable legal and safety requirements. The air handling unit is an electrical-mechanical device that contains electrical and moving parts, therefore, ignoring the instructions in the manual not only shall invalidate the manufacturer's warranty but can also cause direct damage to property or human health.



- When performing any kind of work, make sure the unit is unplugged from electrical supply.
- Use caution when working near heaters inside or outside the unit, as their surfaces may be hot.
- Do not connect the unit to the power supply network before all the external assemblies are fully installed.
- Do not connect the unit to the electrical supply, if there is visible damage that occurred during transport.
- Do not leave objects or tools inside the unit.
- It is forbidden to operate the unit in the premises where there is a risk of release of explosive substances.
- Use appropriate personal protective equipment (gloves, goggles) when installing or repairing the unit.



This sign means that the product may not be disposed of together with your household waste as defined in Directive (2002/96/EC) and national legislation on the management of WEEE. This product must be disposed of at an appropriate collection point or recycling facility for waste electrical and electronic equipment (WEEE). Improper handling of this type of waste due to hazardous substances inside electrical and electronic equipment can endanger the environment and human health. By helping to ensure proper disposal of this product, you will also contribute to the efficient use of natural resources. For more information on how to dispose of such waste for further recycling, contact your city authorities, waste management organisations, approved WEEE systems or your household waste management bodies representatives.

1.2. Design of the units

Domekt CF is an air handling unit with a counter-flow recuperator (heat exchanger). Lamellas of the heat exchange come in contact with different air flows. Exchange of heat or cold takes place between extracted indoor and fresh outdoor air. If no recuperation is required, the air bypass damper is opened and the heat exchanger is closed. This way the outdoor air passes around the recuperator and enters the premises directly.

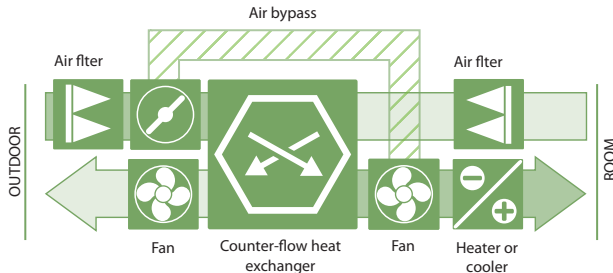

Domekt R – air handling units with a rotary recuperator (heat exchanger). The rotating drum of the rotary recuperator absorbs heat or cold from the air of the premises, transferring it to the fresh outdoor air. If recuperation is not required, the rotation of the rotary heat exchanger is stopped.

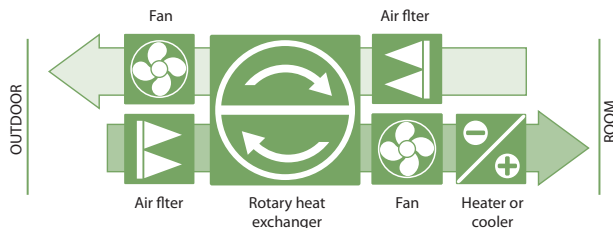

If the capacity of the heat exchanger is not sufficient to reach the temperature set by the user, heaters or coolers may additionally be switched on¹. Heat exchanger and heater (or cooler) are designed to compensate for heating/cooling losses during the ventilation of the premises, thus AHU is not recommended to be used as main heating/cooling source of the building. AHU may not reach the supply temperature setpoint if the actual room temperature differs a lot from the desired value, since in that case heat exchanger capacity will be low.

¹ Depends on the unit components.

Depending on the installation and connection of the ducts, the air handling units are divided into:

- Vertical units – when all ducts are connected at the top.
- Horizontal units – when all ducts are connected on the sides.
- Flat units – thinner units are designed for mounting over suspended ceilings. All ducts are connected at the sides of the unit.

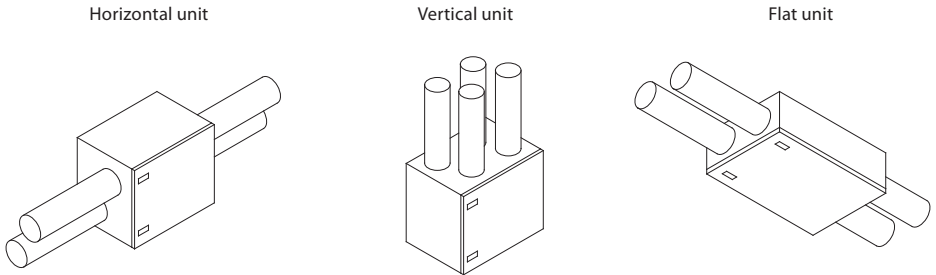

Fig. 1. Classification of units by duct connection

Also, each unit may be left or right inspection side¹. The inspection side indicates which side of the unit contains the air supply duct to the premises.

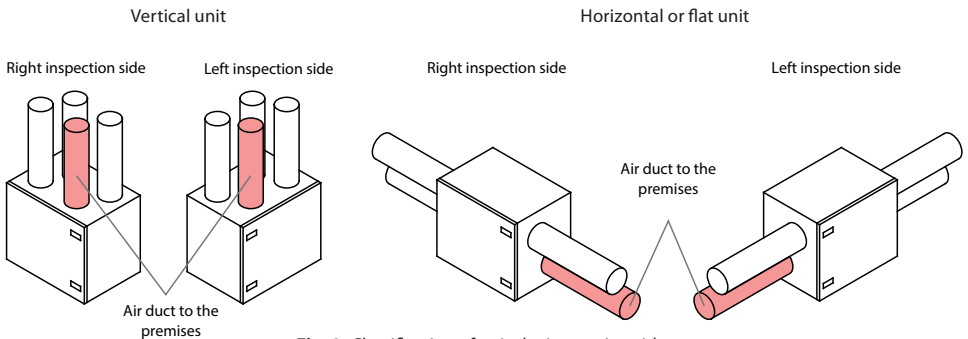

Fig. 2. Classification of units by inspection side

¹ Depends on your order. The exact duct location is shown in the following paragraphs: «Components», «Unit dimensions».

1.3. Components

Below are the principal diagrams of air handling units, including the marking of assemblies of the unit.

1.3.1. Horizontal units

Domekt R 400 H

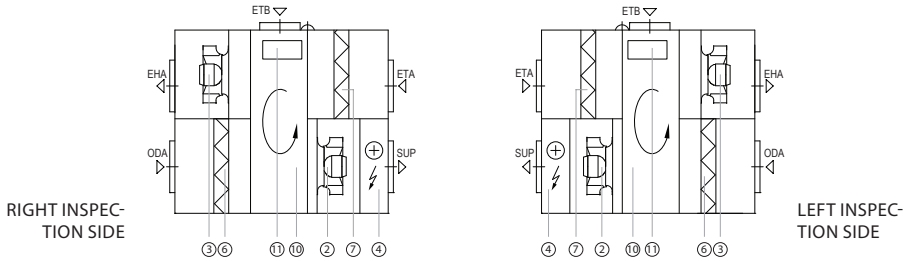

Domekt R 600 H

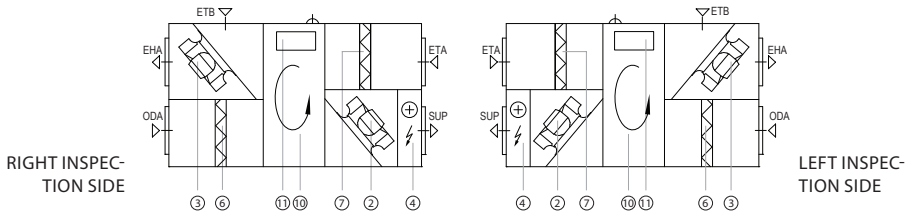

ODA – outdoor air

SUP – supply air

ETA – extract air

EHA – exhaust air

ETB – by-pass extraction without heat recovery

1 – counter-flow heat exchanger

2 – supply air fan

3 – extract air fan

4 – electric heater

5 – electric pre-heater

6 – outdoor air filter

7 – extract air filter

8 – condensate drainage

9 – air bypass damper

10 – rotary heat exchanger

11 – C6M controller main board

Domekt R 700 H

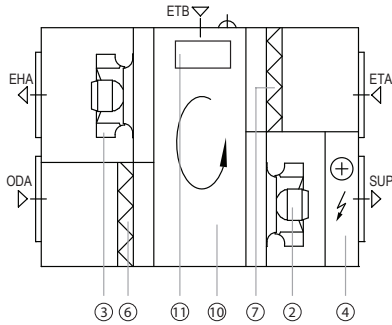

RIGHT INSPECTION SIDE

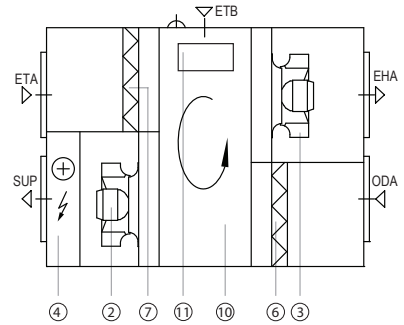

LEFT INSPECTION SIDE

Domekt CF 700 H

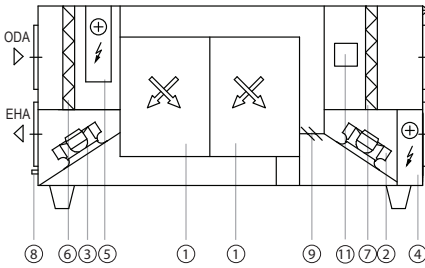

RIGHT INSPECTION SIDE

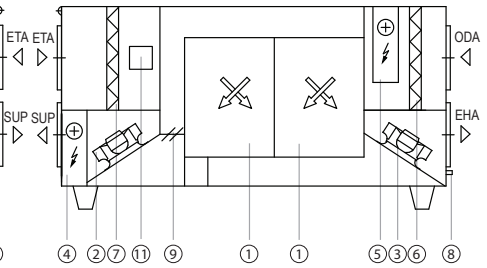

LEFT INSPECTION SIDE

ODA – outdoor air

SUP – supply air

ETA – extract air

EHA – exhaust air

ETB – by-pass extraction without heat recovery

① – counter-flow heat exchanger

② – supply air fan

③ – extract air fan

④ – electric heater

⑤ – electric pre-heater

⑥ – outdoor air filter

⑦ – extract air filter

⑧ – condensate drainage

⑨ – air bypass damper

⑩ – rotary heat exchanger

⑪ – C6M controller main board

1.3.2. Vertical units

Domekt CF 200 V - CF 300 V

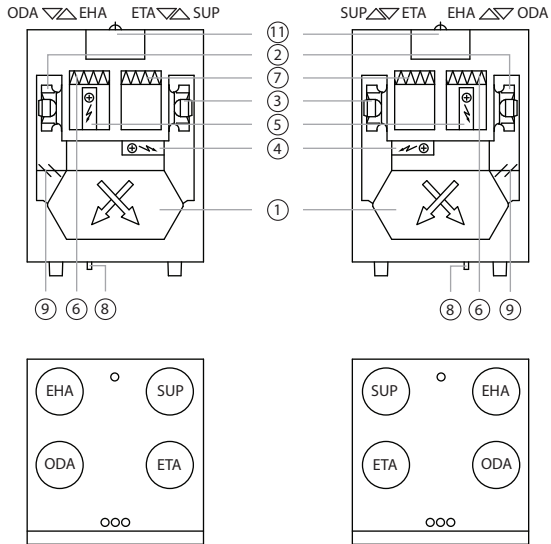

RIGHT INSPECTION SIDE

LEFT INSPECTION SIDE

Domekt R 400 V - R 450 V

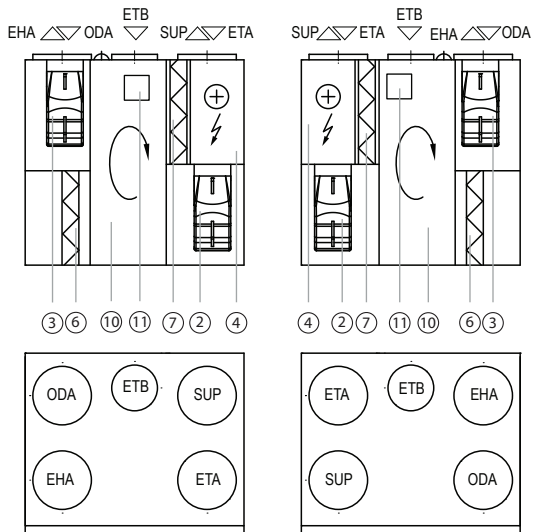

RIGHT INSPECTION SIDE

LEFT INSPECTION SIDE

Domekt CF 400 V

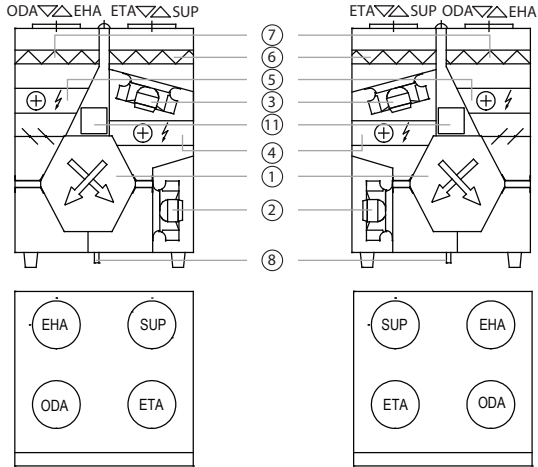

RIGHT INSPECTION SIDE

LEFT INSPECTION SIDE

Domekt R 600 V - R 700 V - R 900 V

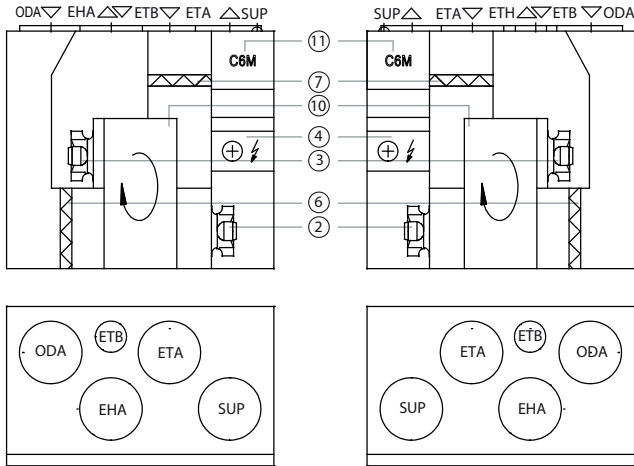

RIGHT INSPECTION SIDE

LEFT INSPECTION SIDE

Domekt CF 700 V

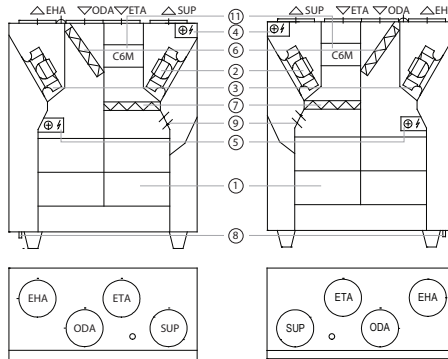

RIGHT INSPECTION SIDE

LEFT INSPECTION SIDE

ODA – outdoor air

SUP – supply air

ETA – extract air

EHA – exhaust air

ETB – by-pass extraction without heat recovery

1 – counter-flow heat exchanger

2 – supply air fan

3 – extract air fan

4 – electric heater

5 – electric pre-heater

6 – outdoor air filter

7 – extract air filter

8 – condensate drainage

9 – air bypass damper

10 – rotary heat exchanger

11 – C6M controller main board

1.3.3. Flat units

Domekt CF 150 F

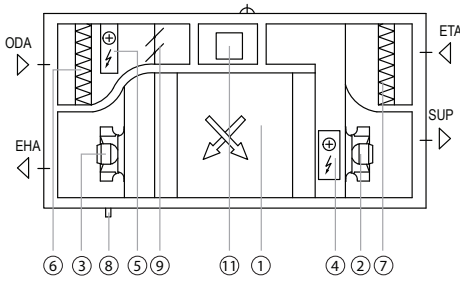

RIGHT INSPECTION SIDE

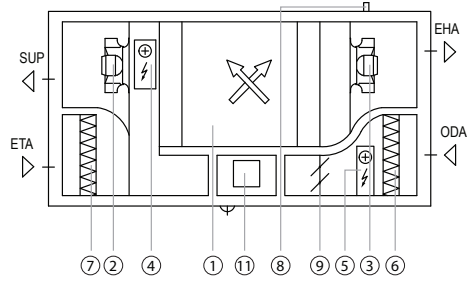

LEFT INSPECTION SIDE

Domekt CF 500 F

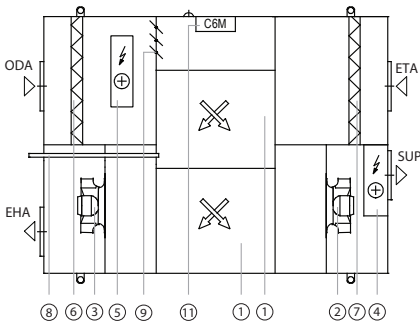

RIGHT INSPECTION SIDE

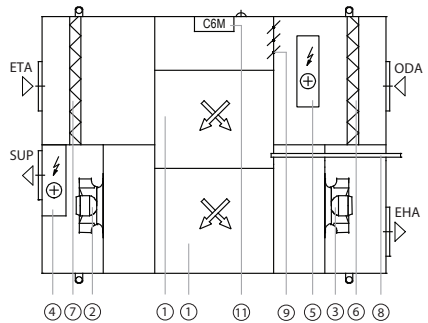

LEFT INSPECTION SIDE

ODA  – outdoor air

SUP  – supply air

ETA  – extract air

EHA  – exhaust air

ETB  – by-pass extraction without heat recovery

① – counter-flow heat exchanger

② – supply air fan

③ – extract air fan

④ – electric heater

⑤ – electric pre-heater

⑥ – outdoor air filter

⑦ – extract air filter

⑧ – condensate drainage

⑨ – air bypass damper

⑩ – rotary heat exchanger

⑪ – C6M controller main board

Domekt CF 700 F

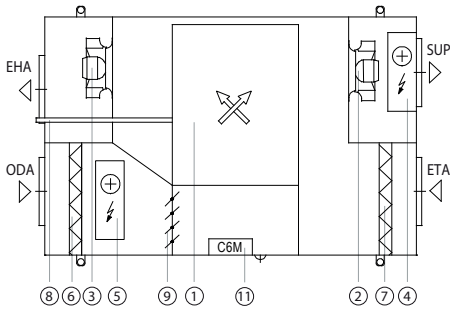

RIGHT INSPECTION SIDE

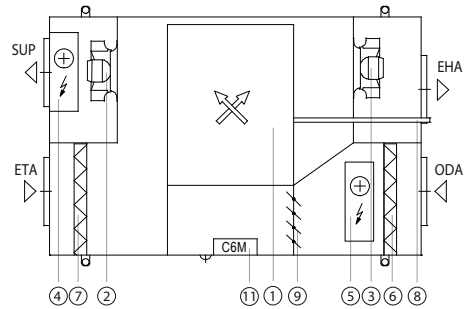

LEFT INSPECTION SIDE

Domekt R 400 F

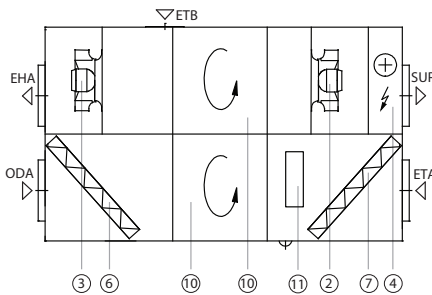

RIGHT INSPECTION SIDE

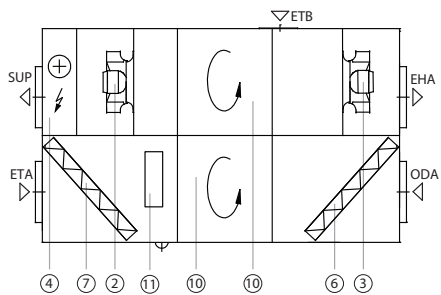

LEFT INSPECTION SIDE

ODA  – outdoor air

SUP  – supply air

ETA  – extract air

EHA  – exhaust air

ETB  – by-pass extraction without heat recovery

① – counter-flow heat exchanger

② – supply air fan

③ – extract air fan

④ – electric heater

⑤ – electric pre-heater

⑥ – outdoor air filter

⑦ – extract air filter

⑧ – condensate drainage

⑨ – air bypass damper

⑩ – rotary heat exchanger

⑪ – C6M controller main board

Domekt R 700 F

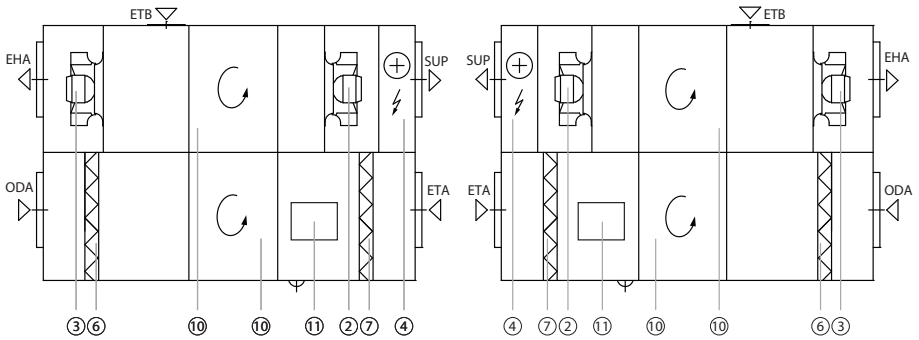

RIGHT INSPECTION SIDE

LEFT INSPECTION SIDE

ODA - outdoor air

SUP - supply air

ETA - extract air

EHA - exhaust air

ETB - by-pass extraction without heat recovery

① - counter-flow heat exchanger

② - supply air fan

③ - extract air fan

④ - electric heater

⑤ - electric pre-heater

⑥ - outdoor air filter

⑦ - extract air filter

⑧ - condensate drainage

⑨ - air bypass damper

⑩ - rotary heat exchanger

⑪ - C6M controller main board

2. UNIT TRANSPORTATION AND STORAGE

Equipment must be transported and stored in the original packaging. During transportation, equipment must be properly secured and further protected against possible mechanical damage, rain or snow.

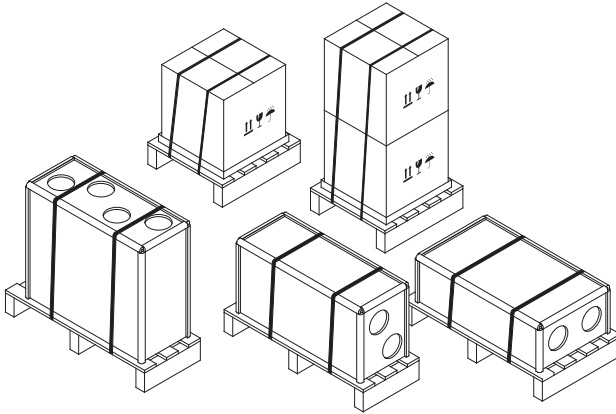

Fig. 3. Examples of equipment packaging

Forklift truck or crane can be used for loading or unloading. For the crane operation, special lashes or ropes must be used to securing them in the designated areas. Ensure that lifting lashes or ropes do not crush or otherwise damage the housing of the unit. We recommend using special belt supports. When lifting and transporting the equipment with a forklift, the forks must be long enough to prevent the unit from being overturned or mechanically damaging its bottom side. Air handling units are heavy, therefore, be careful during lifting, moving or transportation. Use personal protective equipment. Even small units should be transported on a forklift, a trolley or carried by multiple persons.



Fig. 4. Examples of transportation by crane, forklift and trolley

After delivery of the air handling unit, carefully inspect its packaging for damage. If mechanical or other damage is visible (e.g., wet cardboard packaging), notify the carrier immediately. If the damage is significant, do not accept the unit. Inform the selling company or the representative of UAB KOMFOVENT within three business days about any damage detected during delivery.¹

Units should be stored in a clean, dry room at a temperature of 0–40 °C. When selecting a storage location, make sure the unit is not accidentally damaged, that other heavy objects are not loaded on top and dust or moisture does not get inside the unit.



Before installation AHU must be stored in clean and dry premises in their original packaging. If the unit is installed but not yet in use, all connection openings must be tightly closed and the unit must be additionally protected against environmental influences (dust, rain, cold, etc.).

3. MECHANICAL INSTALLATION

3.1. List of parts in the package

Before installing the unit, check for any missing parts. If something is missing from the list, contact the company that sold the air handling unit.

1. Air handling unit.
2. Control panel C6.1 or C6.2².
3. Control panel cable (connected to the unit).
4. Unit suspension brackets³.
5. Mounting bolts for brackets³.
6. Supply air temperature sensor (B1).⁴
7. User guide.
8. Installation manual.

3.2. Installation site requirements

DOMEKT units are designed for installation in household or technical rooms with an air temperature of 0 °C to +40 °C, relative humidity from 20% to 80% (non-condensing). It is recommended to install the air handling unit in a separate room or in an insulated attic on a solid, level base with vibration damping mat. We recommend not to rest the unit against the wall to prevent noise or vibration and accumulation of moisture or mould on the wall due to condensation.

¹ UAB KOMFOVENT is not responsible for losses caused by the carrier during transportation and unloading.

² Depends on your order.

^{3,3} Only for units to be mounted on the wall or ceiling.

⁴ Except for CF 150 F, CF 200 V, CF 300 V units.



It is forbidden to install DOMEKT air handling units outdoors. They are also not designed for ventilation or dehumidification of humid premises (swimming pools, baths, car washes, etc.).



Make sure that children will not reach and will not play with air handling unit without adult supervision.



With additional accessories, DOMEKT R units can also be installed in unheated premises (for example an attic), where ambient temperature is below 0°C. In this case, additional air closing dampers must be installed in the supply and extract air ducts (on the room side). It should prevent warm indoor air from circulating inside the unit when it is stopped to avoid condensation damage to the electronic components. It is also necessary to insulate all ducts passing through unheated rooms.

3.2.1. Maintenance area

When selecting the installation or mounting location of the unit, provide unrestricted and safe access to the equipment for its repair or preventive maintenance. Minimum service area A defines an area, which must be free of any stand-alone or immovable devices, equipment, partitions, structures or furniture. This area is sufficient for performing service and filter replacement works. For repair and replacement of components (e.g., removal of a rotary heat exchanger), access area equal or greater than zone B shall be ensured.

Vertical units

Horizontal units

Flat units

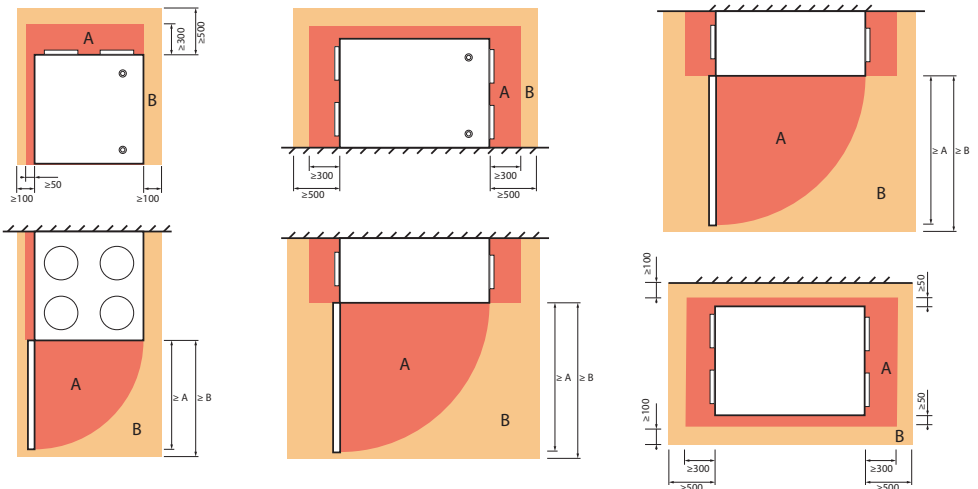

Fig. 5. Minimum space for maintenance

Unit model	A, mm	B, mm
Domekt CF 150 F	1100	1105
Domekt CF 200 V	595	635
Domekt CF 300 V	595	635
Domekt CF 400 V	598	603
Domekt R 400 F	1170	1175
Domekt R 400 H	660	665
Domekt R 400 V	598	603
Domekt R 450 V	680	685
Domekt CF 500 F	1400	1405
Domekt R 600 H	1060	1065
Domekt R 600 V	905	910
Domekt CF 700 F	1365	1370
Domekt CF 700 H	1500	1505
Domekt CF 700 V	1020	1025
Domekt R 700 F	1240	1245
Domekt R 700 H	930	935
Domekt R 700 V	1070	1075
Domekt R 900 V	1070	1075

Make sure to provide a suitable installation location for ceiling-mounted flat units and wall-mounted vertical units. Do not install these devices above stairs or in areas with exceptional ceiling heights, where special equipment would be required to access the unit. In case of the units mounted above the suspended ceiling: service access (if any) for the unit mounted above the suspended ceilings cannot be smaller than the dimensions of the unit or the ceiling must be installed to allow easy dismantling without damaging the structure.



When selecting an installation or mounting location, keep in mind that preventive maintenance works must be performed at least twice a year or more often, therefore, a safe and easy access to the unit must be foreseen.

3.2.2. Humidity in the installation room

If the unit is installed in a room with high humidity, condensation may occur on the walls of the unit in cold weather conditions (see Fig. 6). Newly built flats or homes have high probability of condensation, especially in the first year, until the construction or finishing materials haven't dried up completely. When installing the unit in the rooms with a high probability of condensation, it is necessary to ensure that the condensate does not damage the building structures or furniture.

To reduce condensation on the outside of the AHU, the following is recommended:

- Ensure proper ventilation of the room where the AHU is installed.
- Maintain a lower relative humidity in the room where the AHU is installed.
- Install a pre-heater to increase the air temperature of the outdoor air entering the unit.
- If the air is drier outside, you can increase the ventilation intensity and the temperature settings so that the rooms are dried faster. For this purpose, you can also use the "Humidity control function" (see "Domekt User Guide").

If the unit is shut down in cold outside temperatures, due to free air circulation, condensate can form inside of the unit, therefore, it is important to install air closing dampers (motorized are recommended) to close the air intake and exhaust openings when the unit is OFF. This will prevent cold air from the outside and warm air from the premises to enter the unit.



We recommend that you always keep the unit turned on and use it at minimum of 20% intensity even if no ventilation is required. This will ensure good indoor climate conditions and reduce condensation inside the unit, which might damage electronic components.

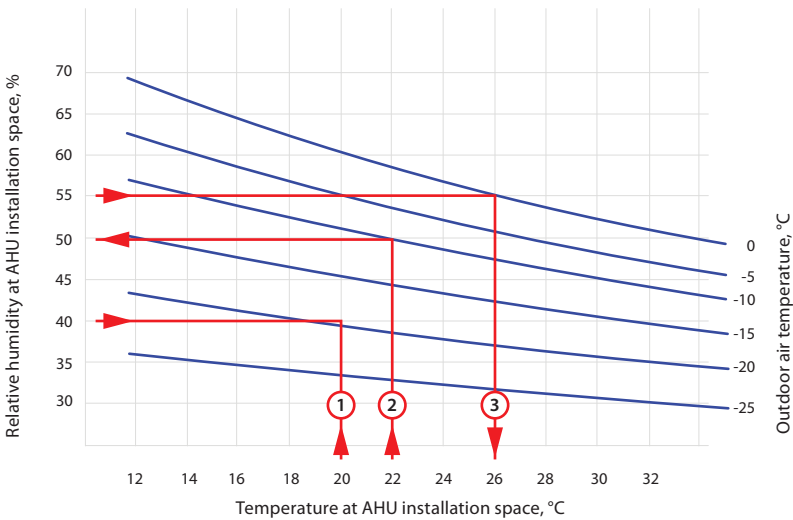

Sample 1

Room temperature 20 °C
 Room relative humidity 40%
 Condensate will form when the outside temperature is below -19 °C

Sample 2

Room temperature 22 °C
 Outdoor temperature -10 °C
 Condensate will form when the room humidity exceeds 50%

Sample 3

Room humidity 55%
 Outdoor temperature 0 °C
 Condensate will form when the room temperature exceeds 26 °C

Fig. 6. Diagram of condensate formation on the exterior surfaces of the air handling unit

Graph in Fig. 6 can be used to determine the conditions under which condensation may occur on the unit. In some spots of the casing (near hinges, locks or duct connections) some condensate may appear even with lower humidity in the installation room, however it is irrelevant for AHU operation.

3.3. Unit dimensions

3.3.1. Vertical units

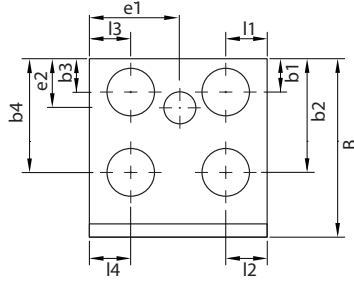
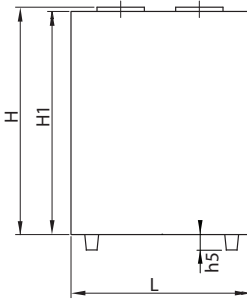

Unit	Inspection side	Dimensions, mm														
		H	H1	L	B	b1	b2	b3	b4	l1	l2	l3	l4	h5	e1	e2
Domekt R 400 V	Right	576	561	598	495	116	347	116	347	101	101	101	101	-	299	95
	Left	576	561	598	495	116	347	116	347	101	101	101	101	-	299	95
Domekt R 450 V	Right	670	655	680	585	116	441	116	441	110	110	130	130	-	355	97
	Left	670	655	680	585	110	435	110	435	130	130	110	110	-	325	97
Domekt R 600 V	Right	764	750	905	610	160	408	160	408	344	149	149	344	-	355	143
	Left	764	750	905	610	160	408	160	408	149	344	344	149	-	550	143
Domekt R 700 V	Right	972	950	1070	637	184	410	184	410	418	177	177	418	-	418	121
	Left	972	950	1070	637	184	410	184	410	177	418	418	177	-	652	121
Domekt R 900 V	Right	972	950	1070	637	184	410	184	410	418	177	177	418	-	418	121
	Left	972	950	1070	637	184	410	184	410	177	418	418	177	-	652	121
Domekt CF 200 V	Right	790	790	595	630	110	360	110	360	110	110	110	110	47	-	-
	Left	790	790	595	630	110	360	110	360	110	110	110	110	47	-	-
Domekt CF 300 V	Right	790	790	595	630	110	360	110	360	110	110	110	110	47	-	-
	Left	790	790	595	630	110	360	110	360	110	110	110	110	47	-	-
Domekt CF 400 V	Right	764	750	598	585	112	379	112	379	139	139	139	139	50	-	-
	Left	764	750	598	585	112	379	112	379	139	139	139	139	50	-	-
Domekt CF 700 V	Right	1144	1130	1020	491	160	325	160	325	410	152	152	410	90	-	-
	Left	1144	1130	1020	491	160	325	160	325	152	410	410	152	90	-	-

3.3.2. Horizontal units

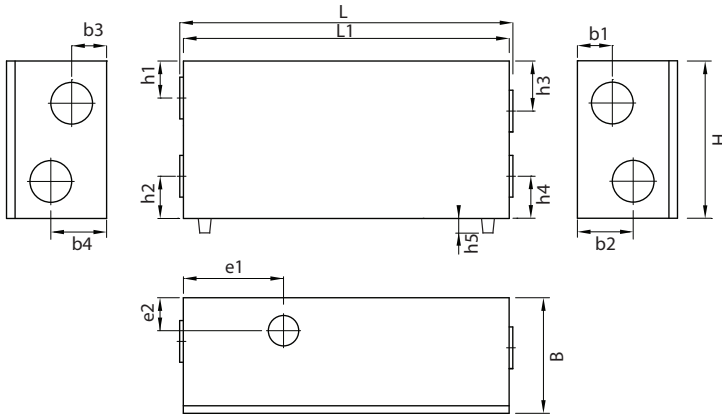

Unit	Inspection side	Dimensions, mm														
		H	L	L1	B	b1	b2	b3	b4	h1	h2	h3	h4	h5	e1	e2
Domekt R 400 H	Right	567	692	660	515	345	140	345	140	173	144	173	144	-	325	121
	Left	567	692	660	515	345	140	345	140	173	144	173	144	-	335	121
Domekt R 600 H	Right	600	1091	1060	570	359	208	208	359	161	151	161	151	-	237	284
	Left	600	1091	1060	570	359	208	208	359	161	151	161	151	-	823	284
Domekt R 700 H	Right	700	963	930	634	195	390	390	195	185	185	185	185	-	465	140
	Left	700	963	930	634	390	195	195	390	185	185	185	185	-	465	140
Domekt CF 700 H	Right	700	1524	1500	487	247	247	247	247	200	200	200	200	90	-	-
	Left	700	1524	1500	487	247	247	247	247	200	200	200	200	90	-	-

3.3.3. Flat units

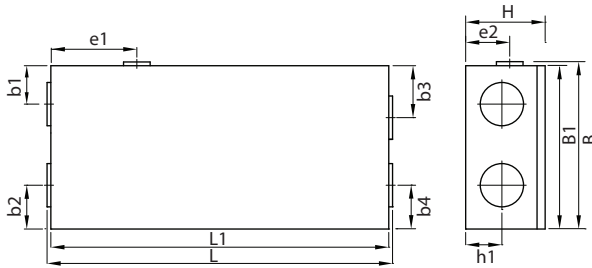

Unit	Inspection side	Dimensions, mm											
		H	L	L1	B	B1	b1	b2	b3	b4	h1	e1	e2
Domekt R 400 F	Right	310	1215	1170	702	700	240	175	240	175	145	392	200
	Left	310	1215	1170	702	700	240	175	240	175	145	778	200
Domekt R 700 F	Right	420	1285	1240	853	850	180	235	180	235	199	410	289
	Left	420	1285	1240	853	850	180	235	180	235	199	830	289
Domekt CF 150 F	Right	294	1100	1100	560	560	147	114	112	195	119	-	-
	Left	294	1100	1100	560	560	195	112	114	147	119	-	-
Domekt CF 500 F	Right	292	1430	1400	1045	1045	283	170	283	400	135	-	-
	Left	292	1430	1400	1045	1045	283	400	283	170	135	-	-
Domekt CF 700 F	Right	344	1406	1365	875	875	266	234	204	234	159	-	-
	Left	344	1406	1365	875	875	204	234	266	234	159	-	-

3.4. Hanging of the units

Smaller vertical units can be hung on the walls, partitions, or other vertical structures. Such units come with their wall mounting brackets and mounting screws. If necessary, use other fixing screws suitable for the specific type of wall or partition (concrete, plasterboard, brick, etc.)

Flat units are usually mounted to ceilings, slab or other horizontal structures with the access door facing downwards. For this purpose, these units have special brackets with integrated vibration absorbers. Brackets are fixed to the supporting structure or slab with threaded rods or anchor bolts. Some flat units can also be hung on the wall or mounted on the floor.

Unit model				
Domekt CF 150 F	+	-	-	-
Domekt R 400 F	+	+	+	+
Domekt CF 500 F	+	-	-	-
Domekt CF 700 F	+	-	-	-
Domekt R 700 F	+	+	+	+

Fig. 7. Installation positions of flat devices



- It is forbidden to drill or screw into the casing of the unit, in places not provided for purpose, as there is a danger of damaging cables or tubes inside the housing.
- Domekt CF 150 F, CF 500 F and CF 700 F flat units must be fitted with a 15 mm slope on the drainage side to facilitate the discharge of condensate from the unit.

If possible, avoid hanging air handling units on thin partitions (especially those made of plasterboard) when it separates the technical room from the living premises, as the vibrations of the device and the noise it emits can be transmitted through. When hanging the unit on plasterboard constructions, we recommend installing additional crossbars at the hanging points and using a double layer of plasterboard. We also recommend filling the partition with noise-dampening materials.

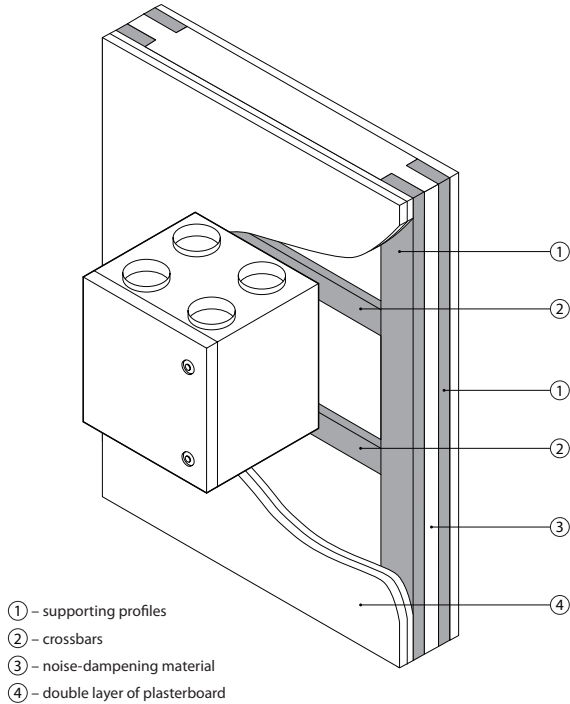

Fig. 8. Mounting the unit on a plasterboard partition

3.4.1. Types and dimensions of suspension brackets

Special brackets, wall screws with plastic bushings and self-tapping screws are provided for mounting the units. When mounting the units, care must be taken to ensure that vibrations of the unit are not transmitted to the building structures, as it may lead to additional noise. In order to eliminate vibrations, additional anti-vibration gaskets are attached to the back wall of the unit. Some units are supplied with factory fitted anti-vibration gaskets; in other cases, they are supplied separately. In case of ceiling-mounted units, vibration absorbers are integrated in mounting brackets.

Below are the types of brackets and their mounting dimensions.

Domekt R 400 V

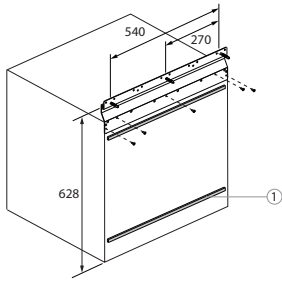

Domekt R 450 V

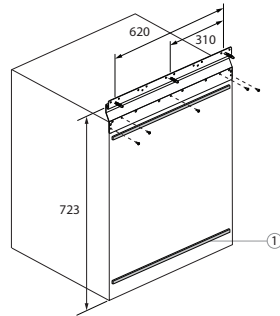

Domekt CF 200 V - CF 300 V

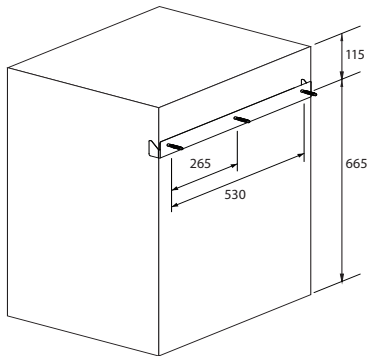

Domekt CF 400 V

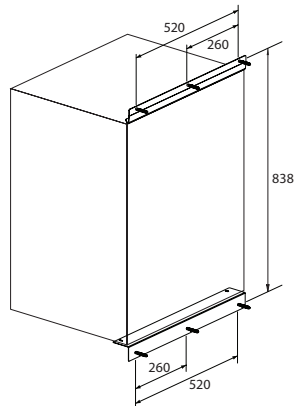

Domekt CF 150 F

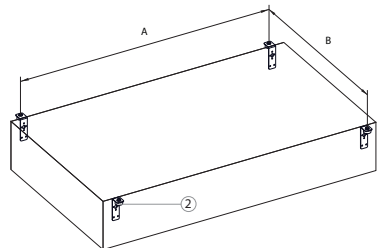
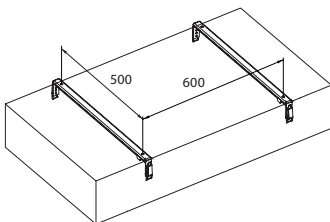

① – Adhesive anti-vibration gasket

② – Rubber vibration absorbers

Unit	A, mm	B, mm
Domekt R 400 F	1100	751
Domekt R 700 F	1024	887
Domekt CF 500 F	1100	1096
Domekt CF 700 F	1100	926

3.5. Duct system installation

The air in and out of the unit flows through the duct system. The duct system should be designed and selected to have low airflow rates and low pressure differentials, ensuring more accurate airflow rates, lower energy consumption, lower noise levels and longer life of the unit.

Outdoor vents must be installed as far apart as possible on different sides of the building to prevent the exhaust air from returning to the air intakes. Try to install the air intake vents where the outdoor air is the cleanest: do not direct them towards the street, car park or outdoor fireplace. We also recommend installing the air intake vent on the north or east side of the building, where the heat of the sun in summer will not have a significant effect on the supply air temperature.

It is highly recommended to install unit connecting ducts of supply inlet and exhaust outlet with a minimum slope on the outside of the premise, to avoid water flowing into the unit in case of rain or snow.

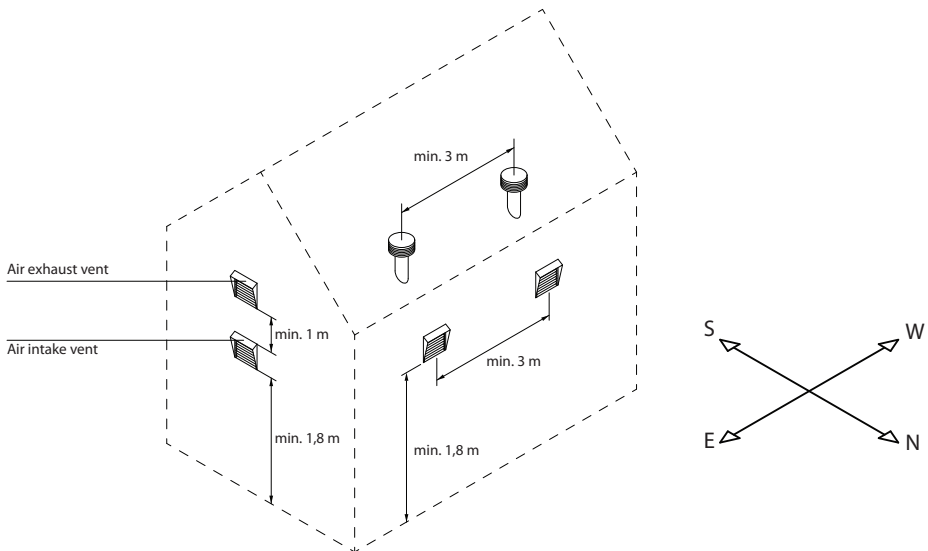

It is recommended to insulate the ducts in unheated rooms (attic, basement) to avoid heat loss. It is also recommended to insulate the supply air ducts if the unit is used for room cooling.

The air ducts are fitted to the unit with self-tapping screws. Different air flow duct positions are marked on the sticker located on the AHU:

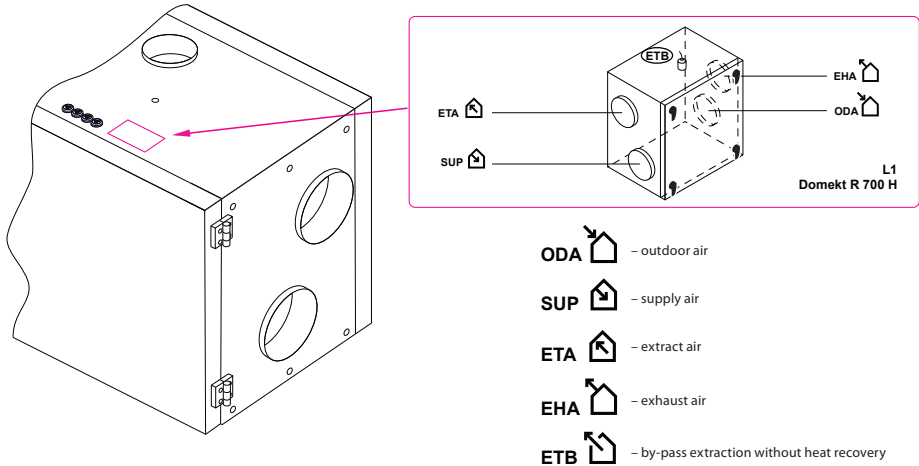

Fig. 9. Air duct marking

Most units with a rotary heat exchanger also have a fifth branch (labelled E) to connect an additional exhaust duct (see 1.3. section). The airflow through this opening is delivered directly to the exhaust fan, bypassing the filters and heat exchanger, therefore, you can connect ducts from the bathroom, toilet, or kitchen in cases when there is no additional extraction fan in these premises. However, air is extracted through an additional branch without recuperation, thus reducing the efficiency of the heat exchanger. For this reason, we do not recommend using the extra air extraction continuously. An additional exhaust duct should be fitted with air closing damper (motorized are recommended) and should only be opened when additional extraction is required (e.g. when bathing). If the additional branch is connected to the kitchen hood with an integrated closing damper, an additional damper is not needed.

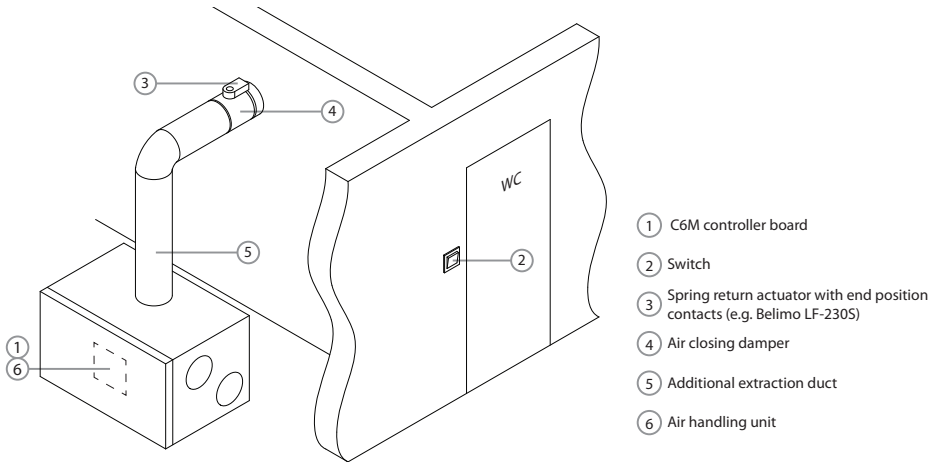

Fig. 10. Example of mounting of an additional air extraction duct



- Ducts connecting the unit to the exterior of the building must be insulated (insulation thickness 50–100 mm) to prevent condensation on cold surfaces.
- Air intake and exhaust ducts must be fitted with air closing dampers (mechanical spring-loaded or electric with actuators) to protect the unit from exposure to climatic conditions when the unit is switched off.
- In order to minimise AHU noise transferring through the ducts into ventilated areas, sound attenuators must be connected to the unit.
- Duct system elements must have separate brackets and to be mounted in a way that their weight is not shifted to the unit casing.
- The kitchen hood with integrated exhaust fan must not be connected to the additional air exhaust duct. Such hood must be connected to a duct separated from the general ventilation system.

The diameter of the ducts varies by unit model:

		Unit						
		Domekt R 400 V Domekt R 450 V Domekt R 400 H	Domekt R 400 F Domekt R 600 H Domekt R 600 V	Domekt R 700 H Domekt R 700 V Domekt R 700 F Domekt R 900 V	Domekt CF 150 F Domekt CF 200 V Domekt CF 300 V Domekt CF 400 V	Domekt CF 500 F Domekt CF 700 V	Domekt CF 700 F Domekt CF 700 H	
Duct diameter, mm	ODA	160	200	250	160	200	250	
	SUP	160	200	250	160	200	250	
	ETA	160	200	250	160	200	250	
	EHA	160	200	250	160	200	250	
	ETB	125	125	125	–	–	–	

3.6. Connection of external heating/cooling units¹

Additionally, you can connect the following to DOMEKT air handling units:

- Water heater.
- Water cooler.
- Direct expansion (DX) cooler/heater.

These accessories are installed in the air supply duct in the premises. All assemblies in the heating or cooling systems must be connected by a qualified specialist.

When connecting the heater/cooler pipes, they must be supported by a box spanner – otherwise they will be damaged. If water is used in the heater, for frost protection water temperature sensor (B5), must be installed. It is screwed into the special hole on the return water pipe. The sensor must be thermally insulated so that the room temperature does not distort water temperature measurements.

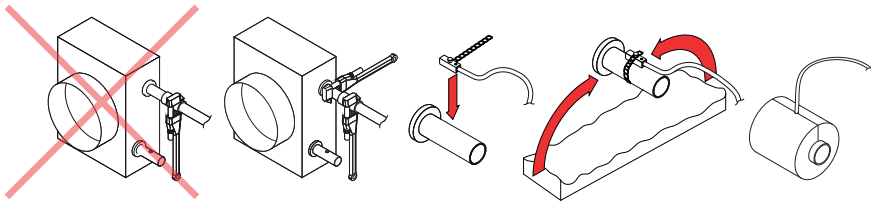

Fig. 11. Connecting the water heater/cooler hoses and installing the water temperature sensor



When operating the unit with negative outdoor temperature, a water-glycol mixture must be used as heat medium in a water heater or cooler or it is necessary to ensure a return water temperature of at least 25 °C.



Pipework package² must include circulation pump, which circulates heating/cooling medium through the coil (smaller circuit) and 3-way mixing valve with modulated actuator. In cases if 2-way valve is used, additionally it must be installed non-return valves to ensure continuous circulation around smaller circuit. PPU must be installed as close to the water coil as possible.

Heat exchanger coil of DX coolers/heaters are factory-filled with nitrogen gas. Before connecting heat exchanger coil to the refrigerant system, the nitrogen gas is discharged through a valve which is then cut off and coil connections are soldered to the pipeline.

¹ Ordered separately.

² It is recommended to use PPU made by Komfovent.

3.6.1. Thermostat function¹

C6.1 control panel can also be used as a room thermostat to turn on/off external heating or cooling devices (e.g., heating boiler, heat pump or air conditioner) according to the temperature of the room where the control panel is installed. Based on the control panel settings, the digital output is activated according to the room temperature (terminals No. 34-37, see "Connection of Electrical Components"). If two control panels are used, you can select different digital outputs on each of the control panels. This will allow activating different heating / cooling devices depending on which control panel temperature does not meet the desired temperature. Thermostat function can also be active when the device is stopped.

Read more about the function and settings in the User Manual.

3.7. Connection of condensate drain

In Domekt CF units with counter-flow plate recuperator, condensate is formed due to the difference between indoor and outdoor temperature, therefore, units of this type are equipped with condensate drip pans and drainage outlets. Due to the negative air pressure in the air handling unit, the water cannot drain out of the condensate collection tray by itself, therefore, it is necessary to connect a siphon or a siphon with a one-way valve to the drain pipe.

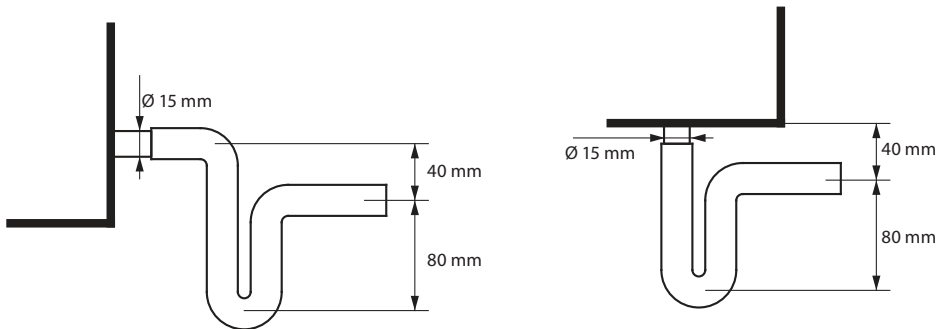

Fig. 12a. Installation of a siphon without one-way valve

¹ C6M controller software version must be C6_1_5_36_54 or later, and for control panel – C6_1_slm_1_1_4_37 or later.

The drainage pipeline must be mounted with a slope, without any constrictions or loops, which might prevent water from draining easily. If the drainage pipeline passes through the outdoors or unheated premises, it must be adequately insulated or equipped with a drainage heating cable to prevent water freezing in winter. Any drainage system cannot be directly connected to the wastewater system in order to prevent the transmission of odours and bacteria into the supply air. Condensate from the drain of the air handling unit must be collected in a separate container or into the sewage grate without direct contact: do not connect drain directly to sewer pipe and do not immerse it into water. The condensate collection point should be easy to clean and disinfect.

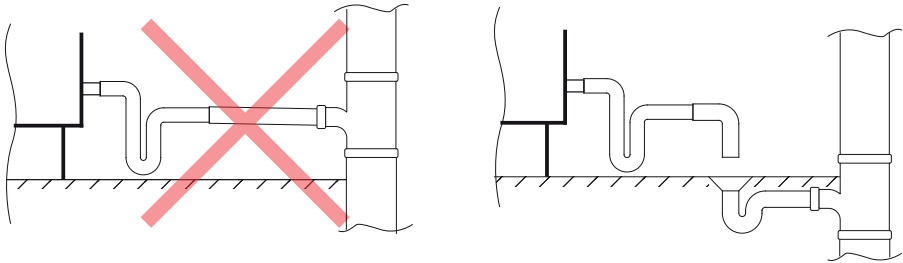

Fig. 12b. Condensate drain connection to sewer system

4. ELECTRICAL INSTALLATION

Electrical work may only be carried out by a qualified electrician in accordance with the instructions given in this manual and in accordance with applicable legal requirements and safety requirements. Before performing electrical component installation:



- Make sure the unit is unplugged from the mains.
- If the unit has been standing in an unheated room for a long time, make sure there is no condensation inside it and check that the connectors and electronic parts of the connectors are not damaged by moisture.
- Check the insulation of the power cable or other cables for damage.
- Locate the electrical diagram of the unit according to the specific unit type.

4.1. Electrical input requirements



- The power supply rating for the unit is 230 V AC, 50 Hz.
- Connect the unit only to suitable power socket with appropriate earthing and meeting the electrical safety requirements.
- It is recommended to connect AHU to the mains via 16 A automatic circuit breaker with 30 mA current leakage protection (type B or B+).
- It is recommended that the control cables be placed at least 20 cm from the power cables, to reduce the possibility of electrical interference.
- All external electrical elements must be connected strictly according to the electrical diagram of the unit.
- Do not disconnect the connectors by pulling them on wires or cables.

4.2. Connecting electrical components

All internal and external unit elements are connected to the main controller board.

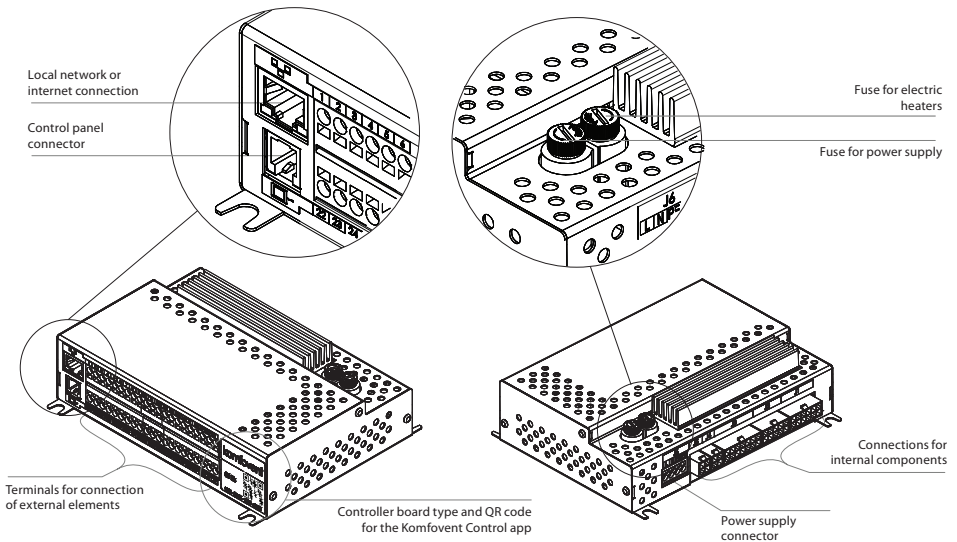

Fig. 13. C6M controller main board

The controller board on the unit may be concealed under the protective cover that must be removed for access to the controller terminals. For the location of the automation box and the controller board, see section 1.3. The terminals of the external elements of the controller board are numbered and are used only to connect optional components and may remain empty if no additional features are required.

B6	Supply air VAV sensor	0..10V	22	1	NTC	Return water temperature sensor	B5
		GND	23	2	10k		
		+24V	24	3	NTC		
B7	Extract air VAV sensor	0..10V	25	4	10k	Supply air temperature sensor	B1
		GND	26	5	C		
		+24V	27	6	NO		
B8	Air quality or humidity sensor 1	0..10V	28	7	NC	Common Control Fire alarm Fireplace Kitchen Override	INPUTS
		GND	29	8	NO		
		+24V	30	9	NO		
B9	Air quality or humidity sensor 2	0..10V	31	10	NO	24V DC; 0..10V output	AUX
		GND	32	11	0..10V		
		+24V	33	12	GND		
OUTPUTS	Common	C	34	13	+24V	External DX unit	DX
	Heating	NO	35	14	+24V		
	Cooling	NO	36	15	0..10V		
	Alarm	NO	37	16	GND		
FG1	Air damper actuators Max. 15 W	~	38	17	0..10V	Water mixing valve actuator	TG1
		~230V	39	18	GND		
		N	40	19	+24V		
S1	Water pump Max. 100 W	~230V	41	20	A	Modbus RTU	RS485
		N	42	21	B		

Fig. 14. Terminals for connecting external elements of C6M board



- The terminal numbering shown here only applies for C6M controller board. Before connecting the external elements, check the board type on the sticker in the front of the controller (see Fig. 13).
- The total power of external elements using 24 V voltage may not exceed 30 W.
- All cables from external components must be routed through the rubber grommets. To seal the cable correctly, do not make an "X" cut or too large hole in the grommet.
- Condensate inside of the unit may flow over surface of the cable in to the terminals of main board and cause damage to the electronics. To avoid that, please leave the cables of external components a bit longer and make a small loop inside of the unit.

- **B5 (1–2)** – for duct mounted water heater, a return water temperature sensor must be installed to protect against freezing (see section 3.6).

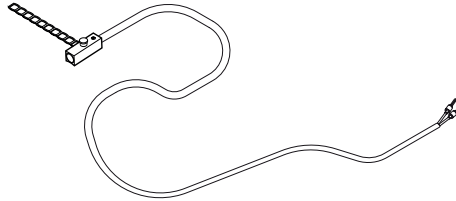

Fig. 15a. Water temperature sensor

- **B1 (3–4)** – for supply temperature to be seen, duct mounted temperature sensor should be connected. Without temperature sensor AHU will operate normally, however supply temperature will not be displayed on the control panel. On some units¹ the supply air temperature sensor inside of the unit is already connected. If additional duct-mounted heating/cooling devices are used, the internal temperature sensor (if used) should be disconnected and a separate duct supply air temperature sensor must be installed instead. In the duct, the sensor must be installed downstream all heating/cooling units at a distance of at least two duct diameters from the nearest heat exchanger coil.

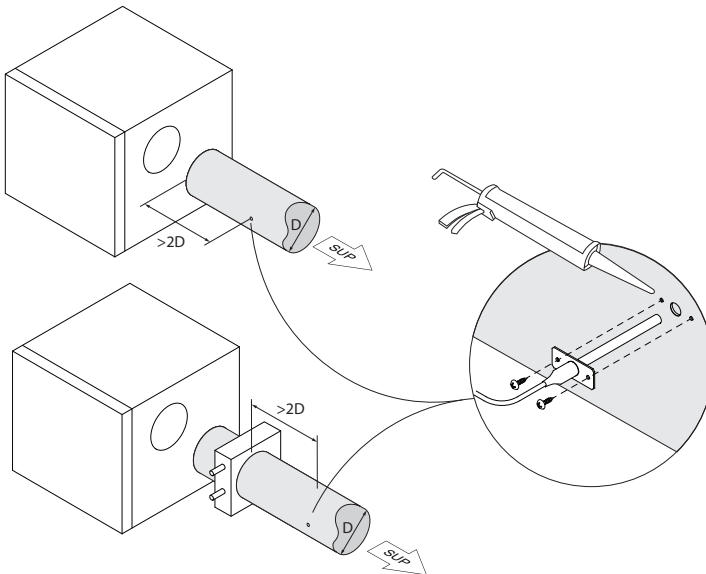

Fig. 15b. Installation of a supply air temperature sensor

¹ Only in CF 150 F, CF 200 V, CF 300 V units.

- Inputs (5–10)** – to switch between the “Kitchen”, “Fireplace”, “Override” ventilation modes (see “Domekt User Guide”), connect the respective terminals together with the common terminal 5 (ventilation modes will operate until the terminals are connected). To activate these modes, a switch, a motion detector or kitchen hood with normally open contacts (NO) can be connected to the terminals. Each function may have a separate switch.

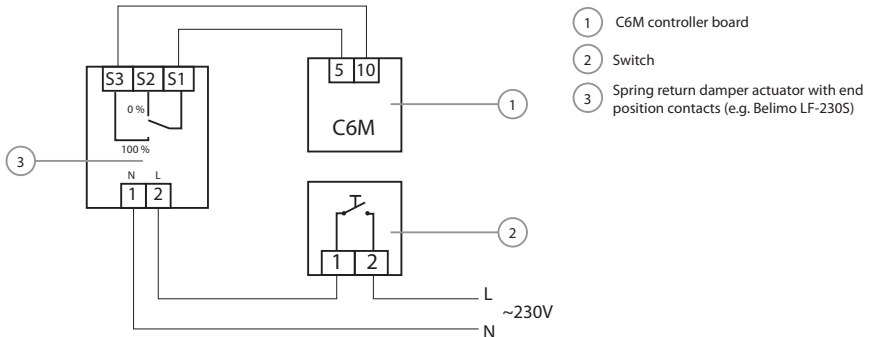

Fig. 16. Example of “Override” ventilation mode activation when using additional air extraction with a motorised damper (see Fig. 10)

Fire alarm requires a normally closed contact (NC), therefore, a jumper is connected between terminals 5 and 7, instead of which, building fire system can be connected. When the contact is disconnected, the unit is stopped and a fire alarm message is displayed. The control terminal 6 is required for switching between heating and cooling functions when the duct is equipped mounted water heater is used for both heating and cooling. When in the settings “External coil” type is selected as “Auto” (see “Domekt User Guide”), the water mixing valve and the water pump will be controlled by the heating signal if terminals 5/6 are open, and by cooling signal if the terminals are closed. For example, a thermostat can be connected here to close the terminals when cold water circulates in the system.

- AUX (11–14)** – can be used for connection of additional elements that require a 24 V power supply and when there are no dedicated terminals (for example, to connect a second control panel). 0...10 V signal is used to control an external heater installed in the duct upstream the unit when “External coil” is selected in the “Frost protection” settings (see “Domekt User Guide”) and electrical pre-heater installed in the unit is not used.
- DX (15–16)** – control signal for external direct expansion (DX) cooler/heater.
- TG1 (17–19)** – power and control signal for the mixing valve actuator of the external heat exchanger for mixing. Depending on the “External coil” type selected in the settings (see “Domekt User Guide”), the valve actuator will be controlled by a heating or cooling signal.
- RS485 (20–21)** – here it can be connected:
 - Control panel (see. Fig. 17)
 - Data cable for a building management system, working via Modbus RTU protocol.
 - Fire dampers controller.¹
- B6/B7 (22–27)** – if VAV airflow control method is used (see “Domekt User Guide”), it requires the installation and connection of optional pressure sensors in the ducts. Follow the manufacturer’s instructions when installing VAV pressure sensors. Also, these terminals are used for DCV airflow control when a separate 0...10 V signal can be used to adjust the ventilation intensity (see “Domekt User Guide”).

¹ Optional fire damper controller must be configured and connected. Refer to Fire damper controller manual for more information.

- **B8/B9 (28–33)** – for connection of air quality or humidity sensors for “Air quality” function. When the sensors are connected, its type and connection point must be specified in the settings (see “Domekt User Guide”).
- **Outputs (34–37)** – the terminals are used when external heating/cooling units require an additional closed/open contact (i.e. to start the DX unit). The corresponding contacts are closed depending on whether the air handling unit heats or cools. The alarm signal contact is closed if the air handling unit has critical messages and its operation is stopped.

If the thermostat function is used, you can connect external devices (e.g., heating boiler or heat pump) to these terminals, which will turn on/off when the control panel temperature does not meet the desired temperature. In the function settings on the control panel (see “User manual”), you can select which terminal will be used to switch on the external device. You can also select the signal type: normally open (NO) or normally closed (NC) contact. Based on these settings, terminals 34 + 35, 34 + 36 or 34 + 37 will be activated as soon as the thermostat is activated.



In case of an external DX unit, only ALARM output terminals (34 + 37) can be used for the thermostat function.

- **FG1 (38–40)** – terminals used to connect air damper actuators. 230 V power supply actuators with or without a spring return can be connected to them.
- **S1 (41–42)** – a water circulation pump used in conjunction with external water coils and is activated when required for heating/cooling.

4.3. Control panel installation

The control panel must be installed in a room with:

- ambient temperature – 0...40 °C;
- relative humidity 20% to 80%;
- protection against accidental water droplets.

The control panel can be mounted on a concealed mounting box or directly on the wall – the screws are supplied with the panel. You can also use the magnets on the back to attach the panel to metal surfaces (i.e. on the door of the unit). If possible, mount the control panel in a place with good circulation of the ventilated air. Do not install the control panel inside of cabinets, behind doors, in a corner of a room and avoid direct sunshine. This is very important when room temperature maintenance is used or in CF type AHU's, which uses temperature and humidity sensors inside of the control panel for operation.



Do not use any other size or type of screws but those that are packed together for control panel mounting. Wrong screws may damage the panel's electronics board.

The control panel comes with a 10 m cable. If this cable is too short, you can replace it with a 4x0.22 mm cable, no longer than 150 m.

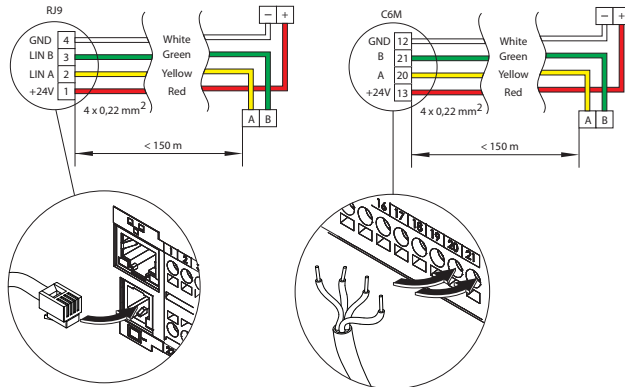

Fig. 17. Control panel cable wiring diagram

It is advisable to run the control panel cable in such a way that it does not go near the power supply wires or high voltage electrical equipment (electrical inlet cabinets, electric water heating boiler, air conditioning unit, etc.). The cable can be passed through the holes in the back or bottom of the control panel (follow the installation instructions supplied with the control panel). The wire to C6M controller board is connected to a dedicated slot (RJ9 connector; see Fig. 13) or to the terminals for external connections.

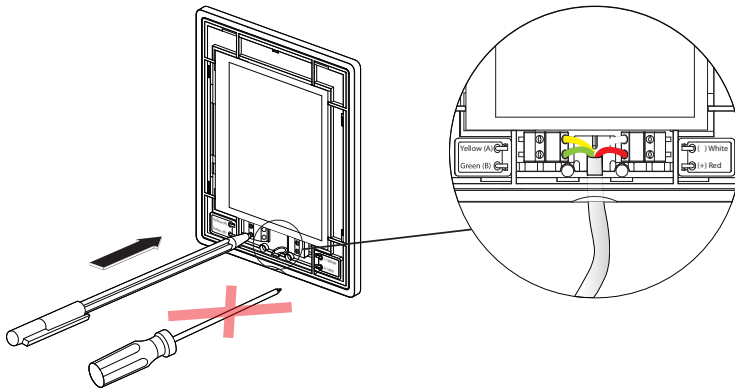

Fig. 18. Cable connection to the control panel



- Do not use sharp tools (e.g. screwdriver) to press on the control panel's contacts. Pencil or ballpoint pen is best for this.
- Do not use any ferrules (or lugs) on the wires to be connected to the control panel, as they may prevent the cable from connecting properly or may damage the panel's connectors.
- To the controller main board connect only the completely assembled control panel with back and front covers installed. If installing covers when the control panel is powered up you may damage the internal electronic components.

4.4. Connecting the unit to an internal computer network or the Internet

The unit can be controlled not only by the control panel, but also by computer or smart phone. In such cases, the air handling unit must be connected to a local computer network or to the Internet. The unit is controlled by a computer using a web browser, or a smartphone with a Komfovent Control app. The air handling unit is connected to the computer network with a CAT5 type cable (RJ45 connector; see Fig. 13). The total cable length between the unit and the network router must not exceed 100 m.

By default, the IP address of the air handling unit is 192.168.0.60, but it can be changed (if necessary) according to the local network parameters. The IP address can be found and changed on the control panel¹.

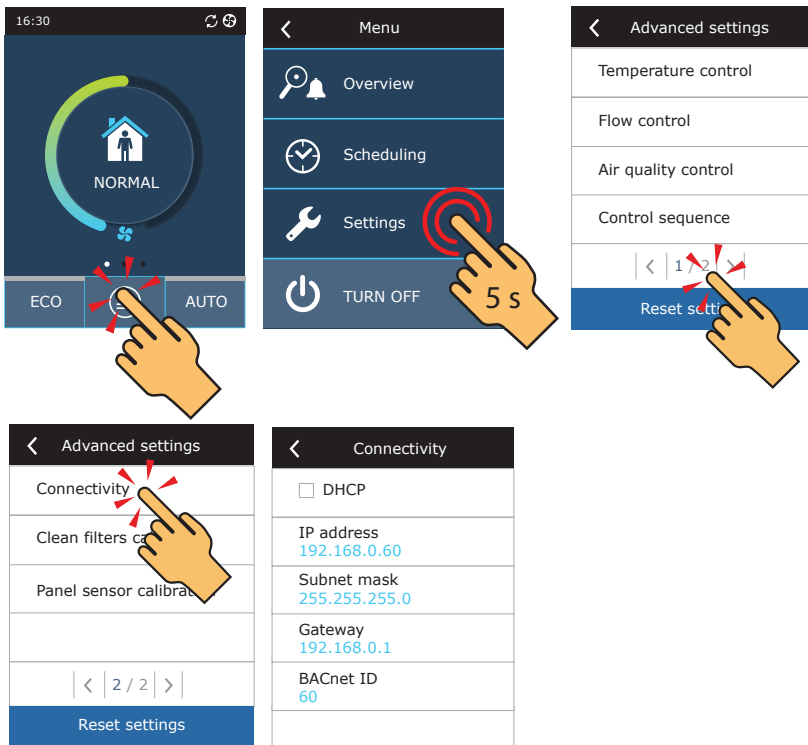

Fig. 19. View and change the IP address of the AHU on the control panel

¹ Only on the C6.1 panel (see Fig. 22).

An air handling unit connected to a network router can be controlled by a computer via a wireless connection (Wi-Fi) on the internal network. After connecting the unit to the network router, activate the DHCP setting on the panel (see Fig. 19). This will automatically assign the unit a free IP address on the local network (do not use this setting if you connect the computer directly to the unit).

When connecting the computer directly to the unit, in the network settings of the computer, it is needed to manually assign an IP address the last number of which would be different from the unit's IP address (for example, if the unit's IP address is 192.168.0.60, assign the address 192.168.0.70 to the computer). Also enter the subnet mask: 255.255.0.0.

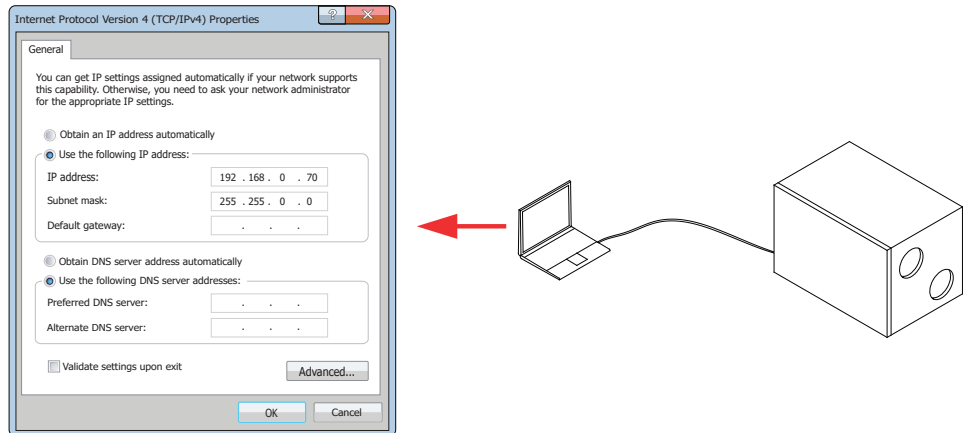

Fig. 20. Computer network settings for direct connection to the unit

To control the unit over the Internet, it must be connected to a network router with Internet access. Subsequent settings vary depending on whether the unit is controlled by a computer or a smartphone.

- The easiest way to manage your unit over the internet is to use a smartphone with the Komfovent Control app. Launch the app on your phone (the phone must have Internet access). When you connect for the first time, the app will ask you to scan the QR code at the front of the controller board (see Fig. 13). When you scan the code, the app will automatically establish the connection to the unit (for more information on the Komfovent Control app, see "Domekt User Guide").
- You will need to change more settings to control your unit over the Internet using your computer. First, port forwarding must be configured to the IP and port number of the unit 80, according to the instructions of the network router. When you connect to the internet with a computer, you will have to enter an external router IP address and the port number in the Internet browser to point to the user interface of the air handling unit (see "Domekt User Guide" for more information on computer control).

Connection over the Internet

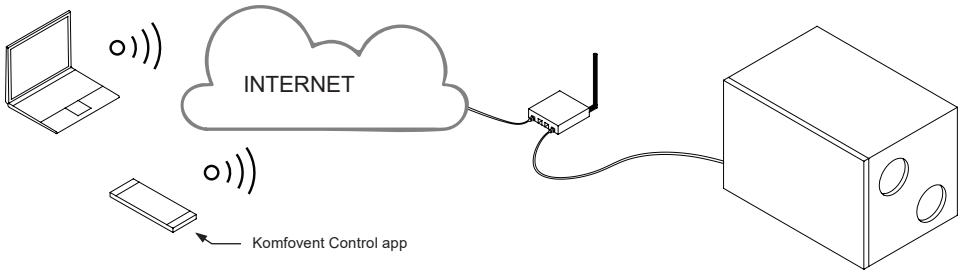

Fig. 21. Examples of unit connection to a local network or the Internet

5. STARTING AND CHECKING THE UNIT

Check for any foreign objects, garbage, or tools inside the unit before turning it on. Check that air filters are installed, or that condensate drainage is connected (if required), and fill the siphon with water. Inspect the duct system for unnecessary obstructions such as fully closed diffusers, regulation dampers, check that outdoor air grills are not blocked.



The operation, maintenance or repair of the air handling unit is prohibited for people (including children) with mental, physical or sensory disabilities, as well as for persons without sufficient experience and knowledge, unless supervised and instructed by the person responsible for their safety in accordance with these instructions.



- The air handling unit can only be started when it is fully installed, with ducts and external electrical elements connected. Do not start the unit without duct system, as this may distort the measurement of the airflow required for stable fan control.
- Do not use the unit with a temporary electrical power supply as unstable power can damage the electronic components.

The air handling unit can be equipped with one of two control panels¹:

- C6.1 control panel with touch screen and colour display. Many functions and settings of the AHU can be reviewed and adjusted on the panel.
- C6.2 control panel with touch buttons that can only switch between basic ventilation modes and settings.

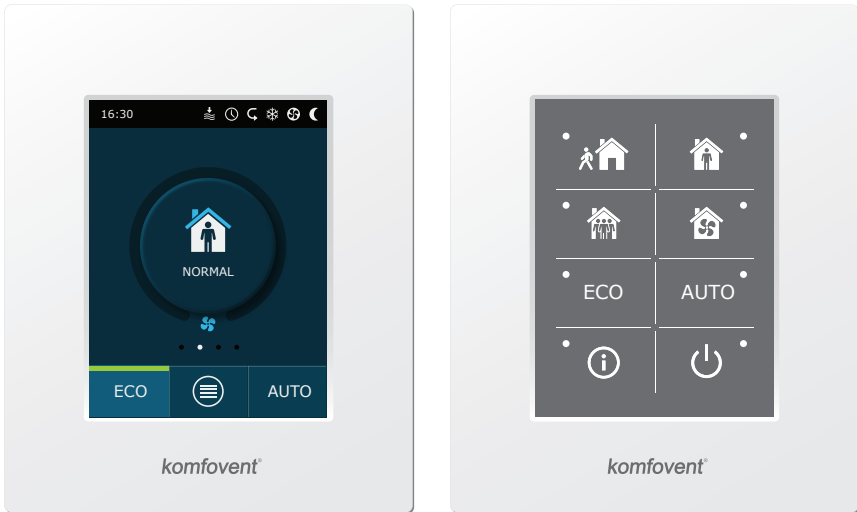





Fig. 22. Control panels C6.1 and C6.2

By default, the following standard ventilation modes are preprogrammed in the unit:

				
	AWAY	NORMAL	INTENSIVE	BOOST
Ventilation intensity	20%	50%	70%	100%
Set temperature	20°C	20°C	20°C	20°C

¹ Depends on your order.

5.1. Control panel C6.1

If the unit is connected to the mains, you will see a home screen or a screen saver on the control panel. Touching screen saver on the panel display will return it to the home screen.

To turn on the air handling unit:

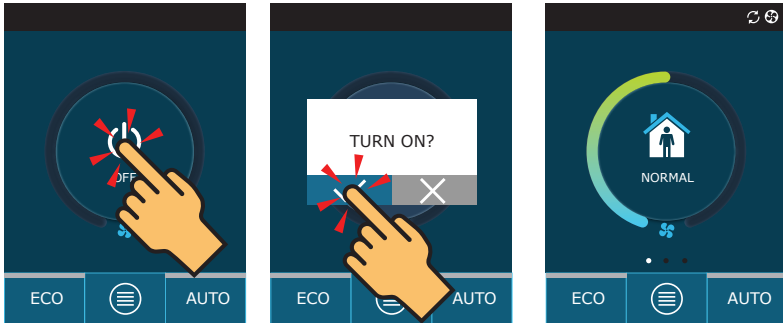

During the first minute after start-up, the automation of the unit will evaluate the unit settings, check the automation components and open the air dampers (if the duct system is equipped with air dampers with actuators). Afterwards a signal to the fans will be given and the unit will start operating in the last used ventilation mode.

To change the ventilation mode:

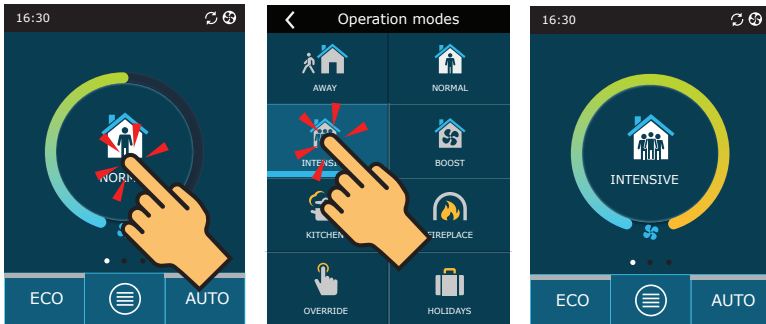

To turn off the air handling unit and return to the home screen:

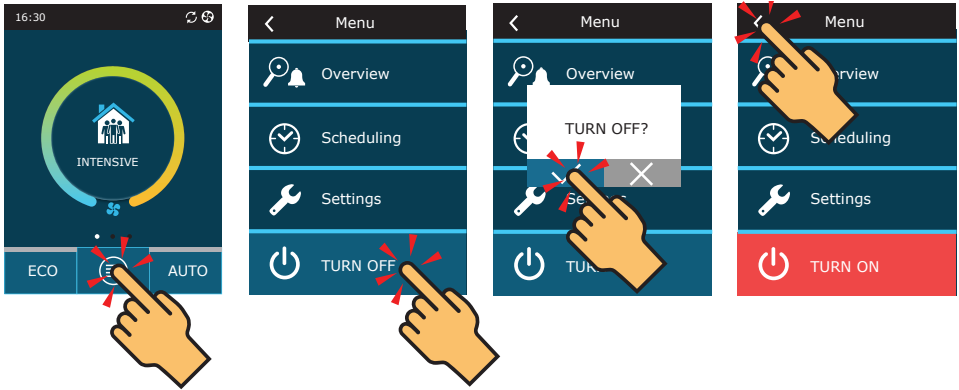

5.2. Control panel C6.2

If the unit is connected to the mains and is currently stopped, a red indicator next to the power button will light up.

To turn ON/OFF the AHU or select the operating mode:



Press the desired operating mode button.

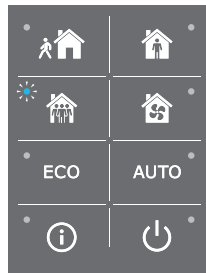

The blue indicator light will be on next to the active mode.

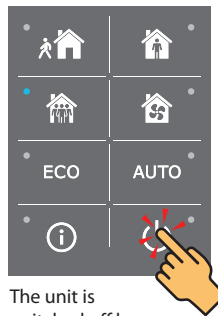

The unit is switched off by pressing the On/Off button.

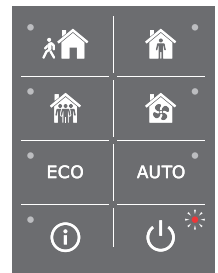

When the unit stops, the red indicator light will be lit next to the On/Off button.

5.3. Start-up of the unit using a computer

If the unit was ordered without a control panel, it can be started by using a computer. The unit is controlled by a computer using a web browser. Connect the computer directly to the air handling unit or to the computer network to which the air handling unit is connected as described in section 4.4. Disable the use of all proxy servers that may block the connection to your unit in Internet browser settings. Enter the IP address of the unit in your web browser:



Log in to the C6 controller user interface: enter the user name *user*, password *user*¹ and press the "Login" button.

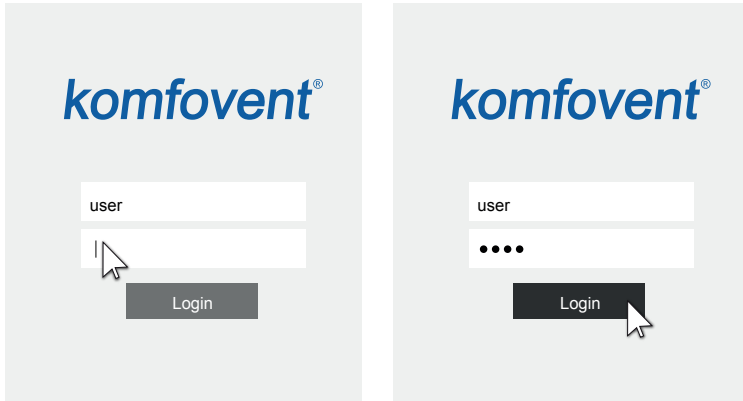

¹ Should you forget a changed password, it can be reset to the initial "user". To do this, you must restore the factory settings for the air handling unit using control panel.

To start the unit, press the required ventilation mode button:

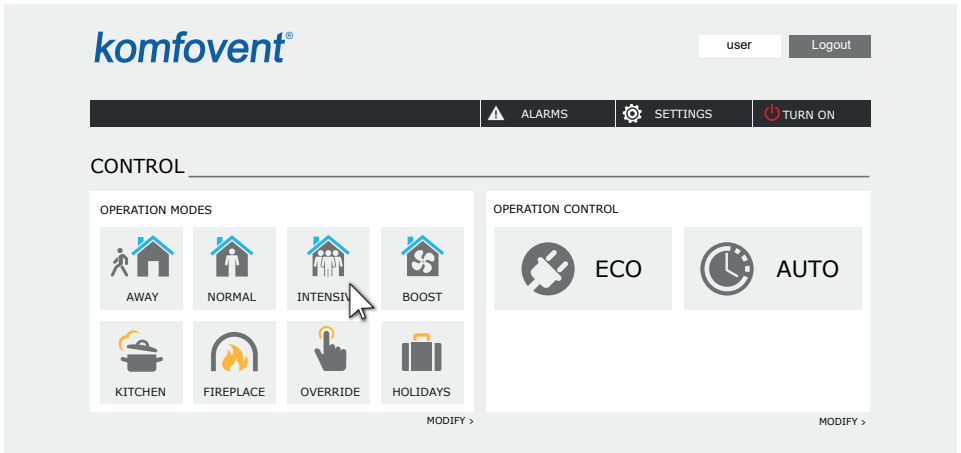

You can stop the unit by pressing the "OFF" button:

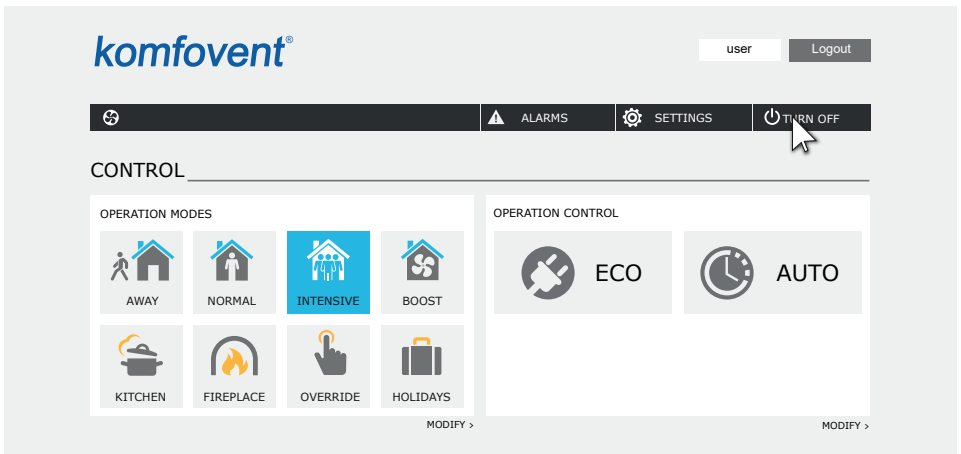

5.4. Quick check

When you start your unit for the first time, check whether:

Task	Yes	No	Notes
The control panel operates responds to touches, and there are no error messages			
The air dampers opens fully			
There are no extraneous sounds and vibrations			
Changing the ventilation modes changes the fan speed			
The unit is airtight without gaps or air leakage			
Heating/cooling devices operates correctly			
External devices connected operates correctly			
The condensate easily flows from the unit and the drainage piping is watertight			

Other notes:

--

Unit installed by	
Company	
Phone	
Date	
Signature	

SERVICE AND SUPPORT

LITHUANIA

UAB KOMFOVENT

Phone: +370 5 200 8000
service@komfovent.com
www.komfovent.com

FINLAND

Komfovent Oy

Muuntotie 1 C1
FI-01 510 Vantaa, Finland
Phone: +358 20 730 6190
toimisto@komfovent.com
www.komfovent.com

GERMANY

Komfovent GmbH

Konrad-Zuse-Str. 2a,
42551 Velbert, Deutschland
Phone: +49 0 2051 6051180
info@komfovent.de
www.komfovent.de

LATVIA

SIA Komfovent

Bukaišu iela 1, LV-1004 Riga, Latvia
Phone: +371 24 66 4433
info.lv@komfovent.com
www.komfovent.com

SWEDEN

Komfovent AB

Ögärdesvägen 12A
433 30 Partille, Sverige
Phone: +46 31 487 752
info_se@komfovent.com
www.komfovent.se

UNITED KINGDOM

Komfovent Ltd

Unit C1 The Waterfront
Newburn Riverside
Newcastle upon Tyne NE15 8NZ, UK
Phone: +447983 299 165
steve.mulholland@komfovent.com
www.komfovent.com

PARTNERS

AT	J. PICHLER Gesellschaft m. b. H.	www.pichlerluft.at
BE	Ventilair group ACB Airconditioning	www.ventilairgroup.com www.acbairco.be
CZ	REKUVENT s.r.o.	www.rekuvent.cz
CH	WESCO AG SUDCLIMATAIR SA CLIMAIR GmbH	www.wesco.ch www.sudclimatair.ch www.climair.ch
DK	Øland A/S	www.oeland.dk
EE	BVT Partners	www.bvtpartners.ee
FR	ATIB	www.atib.fr
HR	Microclima	www.microclima.hr
HU	AIRVENT Légtechnikai Zrt. Gevent Magyarorszá g Kft. Merkapt	www.airvent.hu www.gevent.hu www.merkapt.hu
IE	Lindab	www.lindab.ie
IR	Fantech Ventilation Ltd	www.fantech.ie
IS	Blikk & Tækniþjónustan ehf Hitataekni ehf	www.bogt.is www.hitataekni.is
IT	ICARIA	www.icaria.srl
NL	Ventilair group DECIPOL-Vortvent CLIMA DIRECT BV	www.ventilairgroup.com www.vortvent.nl www.climadirect.com
NO	Ventilution AS Ventistål AS Thermo Control AS	www.ventilution.no www.ventistal.no www.thermocontrol.no
PL	Ventia Sp. z o.o.	www.ventia.pl
SE	Nordisk Ventilator AB	www.nordiskventilator.se
SI	Agregat d.o.o	www.agregat.si
SK	TZB produkt, s.r.o.	www.tzbprodukt.sk
UA	TD VECON LLC	www.vecon.ua