

PPU

PACKAGE UNIT DESCRIPTION

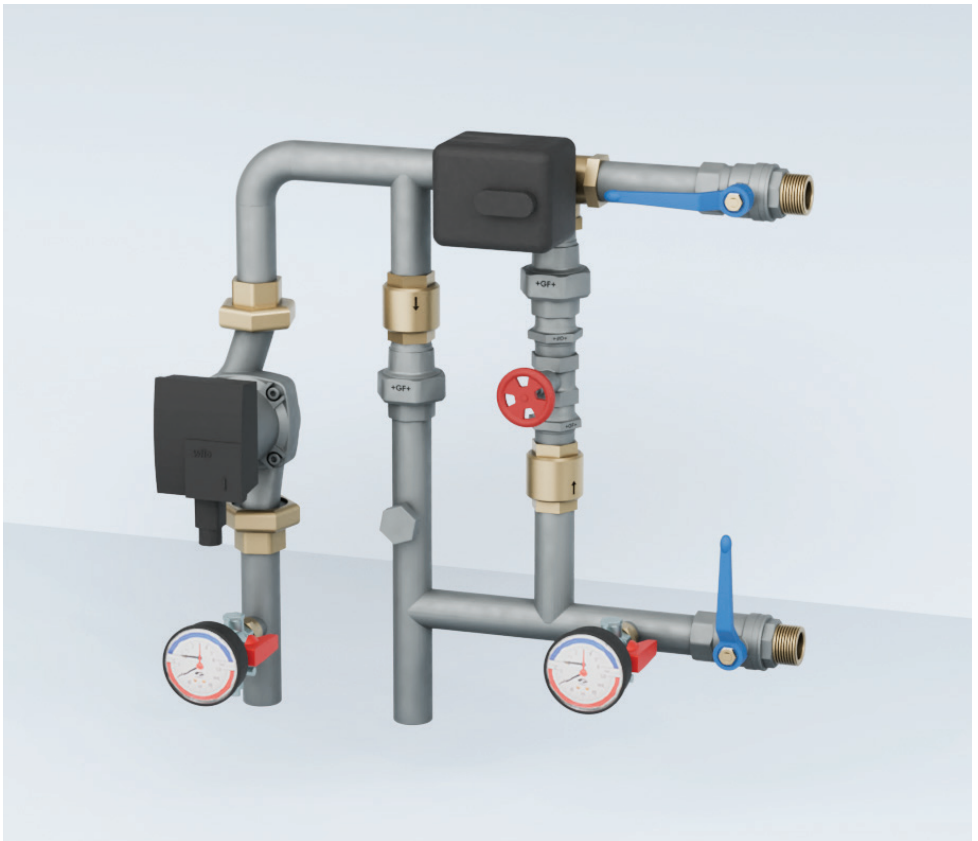

CONTENT

DESCRIPTION OF PIPEWORK PACKAGE UNIT	3
General view	4
Installation diagram	5
DANFOSS AMB 162, AMB 182 ELECTRICAL ACTUATORS	7
Description, main data	7
Electrical wiring	7
The installation of electrical actuator	8
„Right-side“ working mode	9
„Left-side“ working mode	10
ELECTRICAL WATER PUMP	11
Operating knob	11
Operating button	11
Control modes	12
Variable differential pressure ($\Delta p-v$)	12
Constant differential pressure ($\Delta p-c$)	12
Constant pump speed	13
Technical specification	14



This symbol indicates that this product is not to be disposed of with your household waste, according to the WEEE Directive (2002/96/EC) and your national law. This product should be handed over to a designated collection point, or to an authorised collection site for recycling waste electrical and electronic equipment (EEE). Improper handling of this type of waste could have a possible negative impact on the environment and human health due to potentially hazardous substances that are generally associated with EEE. At the same time, your cooperation in the correct disposal of this product will contribute to the effective usage of natural resources. For more information about where you can drop off your waste equipment for recycling, please contact your local city office, waste authority, approved WEEE scheme or your household waste disposal service.

DESCRIPTION OF PIPEWORK PACKAGE UNIT

Pipework Package Unit PPU is used for the adjustment of thermal power of water heaters, i. e. for the adjustment of thermal medium debit via the heater and support the temperature of supplied air.

Pipework Package Unit PPU must be used in a dry room where the temperature from +5 °C to +50 °C is maintained.



In order to install PPU unit outdoors, it must be additionally protected against freezing (e.g. by placing the unit in a thermally insulated cabinet or box) and ensuring constant circulation of hot water or using an antifreeze mixture of water and glycol.

The adjusted thermal medium must be free of dry solids (sand, dirt) or chemical substances as they may harm the mixing unit. No modifications of Pipework Package Unit are allowed because in such case the warranty shall be cancelled.

Prior the installation, the Pipework Package Unit PPU should be transported and stored in original packing. During the transportation, packing protects the Pipework Package Unit against dirt. During the transportation, the product should be protected against mechanical damage, for instance, against impact, falling or vibration. In case of damage due to improper transportation or storage, the warranty shall not apply.

Pipework Package Unit PPU should be installed in a easy accessible location for service and maintenance. Electric wires should not come in contact with the surface of the mixing unit. Pipework Package Unit should be connected to the equipment ensuring its control. The pump rotation can be chosen of three levels. They are adjusted with a switch on the pump body.



PPU – hydraulic tests were not performed with Pipework Package Units!

General view

General view of pipework package unit:

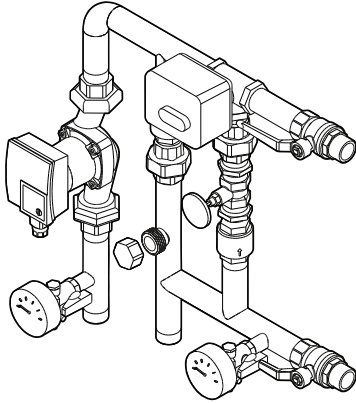

Type A
Kvs ≤ 40

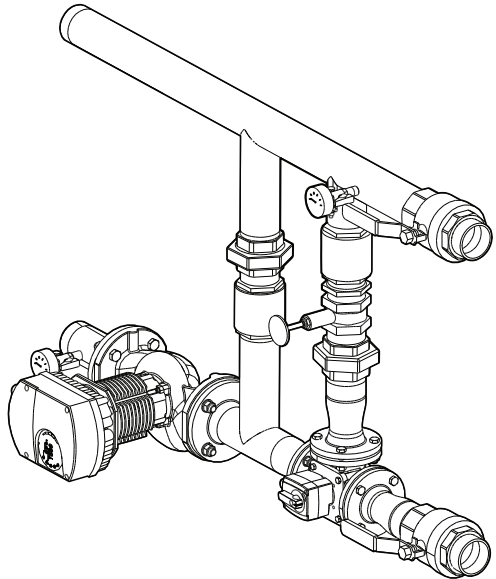

Type B
Kvs > 40

Decoding of marking:

PPU - HW - 3R - 50 - 40 - W8
 1 2 3 4 5 6

1. PPU – Pipework package unit
2. HW – used for heating
CW – used for cooling
3. 3 – three-way mixing valve
R – heating/cooling medium connection from the right
L – heating/cooling medium connection from the left
4. Nominal piping diameter DN, mm
5. Amount of flow (Kvs) through the mixing valve, m³/h
6. Circulation pump type

Installation diagram

The installation diagrams are presented below.

"Left-side" installation

A type Kvs ≤ 40

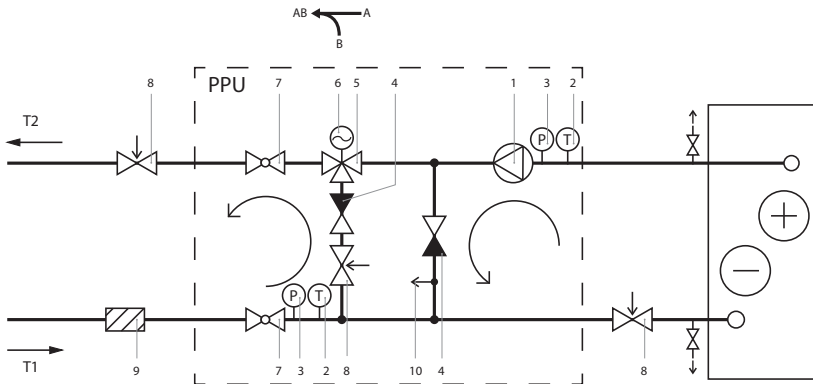

"Right-side" installation

A type Kvs ≤ 40

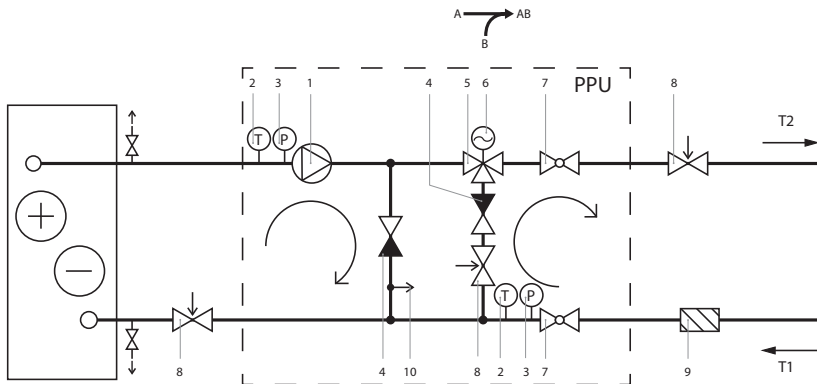

- | | |
|---------------------|--------------------------------|
| 1. Circulation pump | 6. Actuator |
| 2. Thermometer | 7. Ball valve |
| 3. Manometer | 8. Balancing valve |
| 4. One-way valve | 9. Filter |
| 5. Three-way valve | 10. Connection for flow sensor |

RECOMMENDATION: It is recommended to use dismantle joints during installation of Pipework Package Unit in case of emergency disassemble.

"Left-side" installation
 B type Kvs > 40

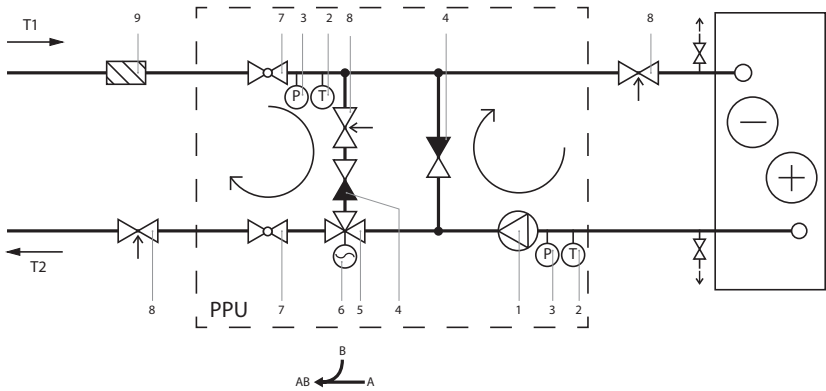

"Right-side" installation
 B type Kvs > 40

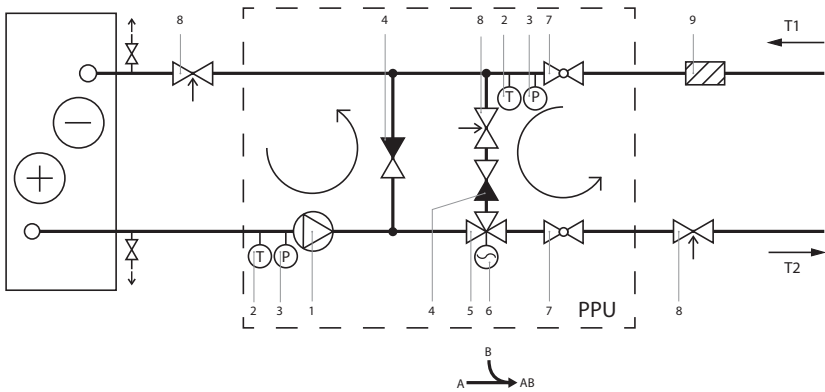

- | | | |
|---------------------|--------------------|--------------------|
| 1. Circulation pump | 4. One-way valve | 7. Ball valve |
| 2. Thermometer | 5. Three-way valve | 8. Balancing valve |
| 3. Manometer | 6. Actuator | 9. Filter |

RECOMMENDATION: It is recommended to use dismantle joints during installation of Pipework Package Unit in case of emergency disassemble.

DANFOSS AMB 162, AMB 182 ELECTRICAL ACTUATORS

Description, main data

AMB 162, AMB 182 actuators is used for temperature control in central heating systems together with 3-way and 4-way rotary valves.



Main data:

- Supply voltage 24 V a.c.
- voltage signal of 0-10 V or 2-10 V.
- Opportunity to control manually.
- With electrical actuator limit of 90°.

Electrical wiring

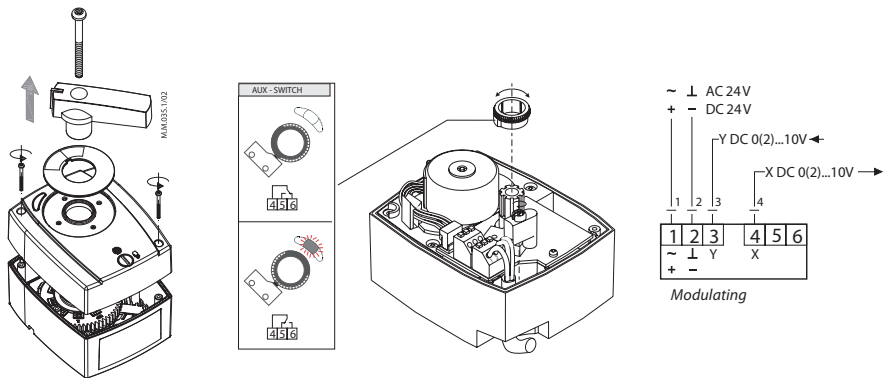

The actuator is wired as the example above depending on actuator type.

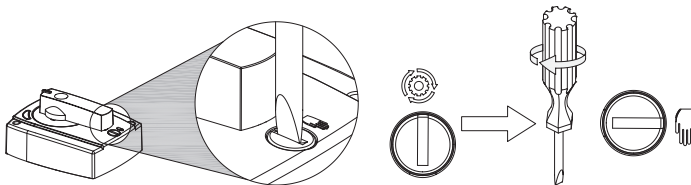

The actuator is switched to automatic mode, controlled by electrical signal, if manual mode was switched on. When automatic mode is switched on, the handle should not be turned by hand. This may damage the actuator.

The installation of electrical actuator

Actuator should be assembled as shown in a picture below.

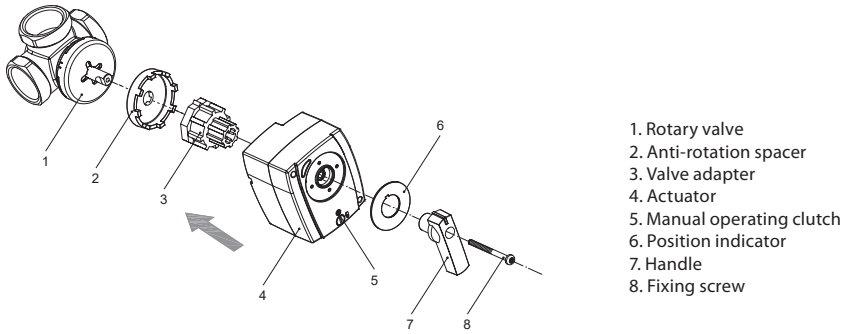

The actuator cannot be mounted upside-down (look at the picture below).

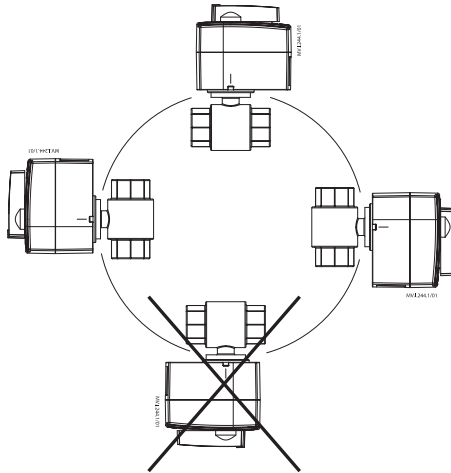

„Right-side“ working mode

The position of axle before installation

Make sure that valve is in correct position before installation. The valve should be in transitional position. The plane on the axis indicates the position of valve. Position indicator should be also mounted in correct position as shown in the picture.

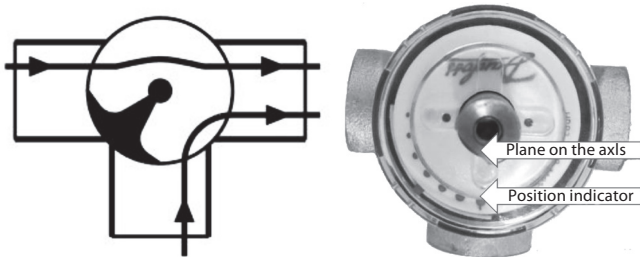

DIP switch setting

DIP switch should be seen when the cover of actuator is removed. Make sure the switch No. 4 is in ON position.

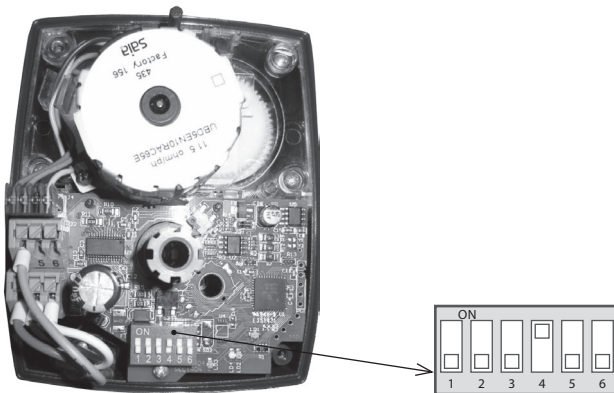

Mounting the handle

Actuator is finished assembling by putting the handle in position as shown in the picture.

The electrical actuator is ready for use.



„Left-side“ working mode

The position of axle before installation

Make sure that valve is in correct position before installation. The valve should be in transitional position. The plane on the axis indicates the position of valve. Position indicator should be also mounted in correct position as shown in the picture.

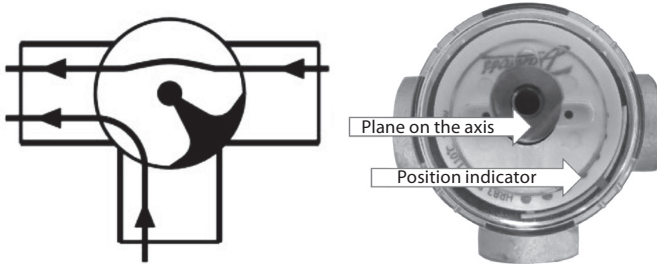

DIP switch setting

DIP switch should be seen when the cover of actuator is removed. Make sure the switch No. 4 is in OFF position.

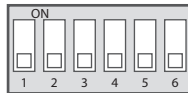

Mounting the handle

Actuator is finished assembling by putting the handle in position as shown in the picture.

The electrical actuator is ready for use.



ELECTRICAL WATER PUMP¹

High-efficiency circulation pump for hot water heating systems with integrated differential pressure control. Control mode and differential pressure (delivery head) are adjustable. The differential pressure is controlled via the pump speed.

Operating knob

- Select control mode.
- Set differential pressure setpoint H.
- Activate the venting function.

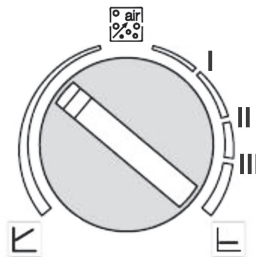

The venting function vents the pump automatically.
The heating system is not vented.

Operating button²

Select control mode or speed by pressing operating button. Indication light will appear near selected mode.

Press and hold for 3 seconds to activate pump venting function.

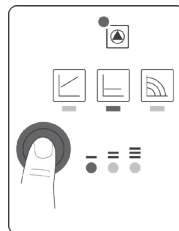

¹ This description/instructions is not valid if a pump of an alternative supplier is chosen for manufactured PPU unit. The pump instructions is included in the kit.

² Only for Wilo-Strata series pumps.

Control modes

Variable differential pressure ($\Delta p-v$)

The differential pressure setpoint H is increased linearly from $\frac{1}{2} H$ to H across the volume flow range. The differential pressure generated by the pump is adjusted to the corresponding differential pressure setpoint.

Note: Recommended for heating systems with radiators to reduce the flow noises at the thermostatic valves.

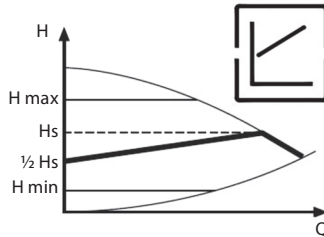

Constant differential pressure ($\Delta p-c$)

The differential pressure is kept constant at the differential pressure setpoint H .

Note: Recommended for underfloor heating, large-sized pipes as well as all applications without changeable pipe system curve (e.g. storage charge pumps).

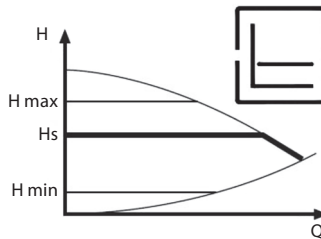

Constant pump speed¹

Recommended for systems with fixed system resistance requiring a constant volume flow. The pump runs in three prescribed fixed speed stages (I, II, III).

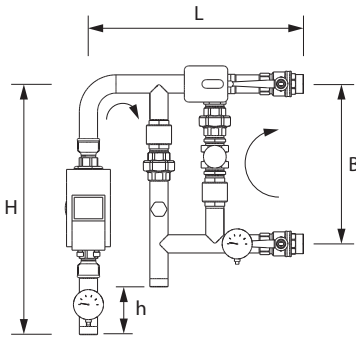
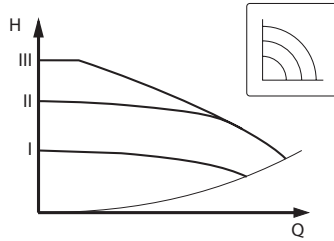

Type A
Kvs ≤ 40

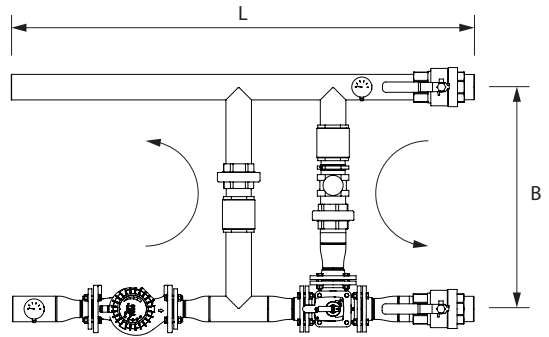

Type B
Kvs > 40

¹ Only for Wilo-Strata series pumps.

Technical specification

DN, mm	Kvs, m ³ /h	Pump type	Current, A	Power, W	Voltage, V	Construction type	B, mm	H, mm	L, mm	h, mm	Connection type
15 (1/2")	0,4	W2	0,22	50	1x230	A	322	426	439	4	Thread
15 (1/2")	0,4	W3	0,5	57	1x230	A	322	498	439	76	Thread
15 (1/2")	0,63	W2	0,22	50	1x230	A	322	426	439	4	Thread
15 (1/2")	1,0	W3	0,5	57	1x230	A	322	498	439	76	Thread
15 (1/2")	1,0	W2	0,22	50	1x230	A	322	426	439	4	Thread
15 (1/2")	1,6	W2	0,22	50	1x230	A	322	426	439	4	Thread
15 (1/2")	1,6	W3	0,5	57	1x230	A	322	498	439	76	Thread
15 (1/2")	2,5	W2	0,22	50	1x230	A	322	426	439	4	Thread
15 (1/2")	2,5	W3	0,5	57	1x230	A	322	498	439	76	Thread
20 (3/4")	4,0	W2	0,22	50	1x230	A	312	500	457	88	Thread
20 (3/4")	4,0	W3	0,5	57	1x230	A	312	510	457	98	Thread
20 (3/4")	4,0	W4	0,55	120	1x230	A	312	510	457	98	Thread
20 (3/4")	4,0	W5	1,5	190	1x230	A	312	510	457	98	Thread
25 (1")	6,3	W2	0,22	50	1x230	A	376	523	490	48	Thread
25 (1")	6,3	W3	0,5	57	1x230	A	376	485	490	10	Thread
25 (1")	6,3	W4	0,55	120	1x230	A	376	485	490	10	Thread
25 (1")	6,3	W5	1,5	190	1x230	A	376	485	490	10	Thread
25 (1")	10,0	W3	0,5	57	1x230	A	376	485	490	10	Thread
25 (1")	10,0	W5	1,5	190	1x230	A	376	485	490	10	Thread
25 (1")	10,0	W6	1,33	305	1x230	A	376	527	490	52	Thread
32 (1 1/4")	16,0	W3	0,5	57	1x230	A	372	580	503	107	Thread
32 (1 1/4")	16,0	W5	1,5	190	1x230	A	372	584	503	111	Thread
32 (1 1/4")	16,0	W6	1,33	305	1x230	A	372	504	503	32	Thread
32 (1 1/4")	16,0	W7	1,33	305	1x230	A	372	564	503	92	Thread
40 (1 1/2")	25,0	W3	0,5	57	1x230	A	403	594	530	92	Thread
40 (1 1/2")	25,0	W5	1,5	190	1x230	A	403	594	530	92	Thread
40 (1 1/2")	25,0	W7	1,33	305	1x230	A	403	537	530	35	Thread
40 (1 1/2")	25,0	W8	2,4	550	1x230	A	403	570	530	68	Thread
50 (2")	40,0	W7	1,33	305	1x230	A	429	653	557	123	Thread
50 (2")	40,0	W8	2,4	550	1x230	A	429	683	557	153	Thread
50 (2")	40,0	W9	2,5	560	1x230	A	429	616	557	87	Thread
50 (2")	44,0	W14	1,8	380	1x230	B	577	-	1370	-	Thread
50 (2")	44,0	W15	1,8	380	1x230	B	577	-	1380	-	Thread
65 (2 1/2")	60,0	W14	1,8	380	1x230	B	660	-	1500	-	Thread
65 (2 1/2")	60,0	W16	2,2	480	1x230	B	660	-	1505	-	Thread
65 (2 1/2")	60,0	W17	1,7	370	1x230	B	660	-	1565	-	Thread
65 (2 1/2")	60,0	W9	2,5	560	1x230	B	660	-	1565	-	Thread
80 (3")	90,0	W17	1,7	370	1x230	B	772	-	1610	-	Thread
80 (3")	90,0	W9	2,5	560	1x230	B	772	-	1610	-	Thread
80 (3")	90,0	W19	2,5	560	1x230	B	772	-	1670	-	Thread

DN, mm	Kvs, m ³ /h	Pump type	Current, A	Power, W	Voltage, V	Construction type	B, mm	H, mm	L, mm	h, mm	Connection type
80 (3")	90,0	W20	3,5	810	1x230	B	772	-	1670	-	Thread
80 (3")	90,0	W22	6	1400	1x230	B	772	-	1520	-	Thread
100/114.3 PN6	150,0	W20	3,5	810	1x230	B	937	-	1965	-	Flange
100/114.3 PN6	150,0	W21	3,5	800	1x230	B	937	-	1995	-	Flange
100/114.3 PN6	150,0	W22	6	1400	1x230	B	937	-	1995	-	Flange

SERVICE AND SUPPORT

LITHUANIA

UAB KOMFOVENT

Phone: +370 5 200 8000
service@komfovent.com
www.komfovent.com

FINLAND

Komfovent Oy

Muuntotie 1 C1
FI-01 510 Vantaa, Finland
Phone: +358 20 730 6190
toimisto@komfovent.com
www.komfovent.com

GERMANY

Komfovent GmbH

Konrad-Zuse-Str. 2a,
42551 Velbert, Deutschland
Phone: +49 0 2051 6051180
info@komfovent.de
www.komfovent.de

LATVIA

SIA Komfovent

Bukaišu iela 1, LV-1004 Riga, Latvia
Phone: +371 24 66 4433
info.lv@komfovent.com
www.komfovent.com

SWEDEN

Komfovent AB

Ögärdesvägen 12A
433 30 Partille, Sverige
Phone: +46 31 487 752
info_se@komfovent.com
www.komfovent.se

UNITED KINGDOM

Komfovent Ltd

Unit C1 The Waterfront
Newburn Riverside
Newcastle upon Tyne NE15 8NZ, UK
Phone: +447983 299 165
steve.mulholland@komfovent.com
www.komfovent.com

PARTNERS

AT	J. PICHLER Gesellschaft m. b. H.	www.pichlerluft.at
BE	Ventilair group ACB Airconditioning	www.ventilairgroup.com www.acbairco.be
CZ	REKUVENT s.r.o.	www.rekuvent.cz
CH	WESCO AG SUDCLIMATAIR SA CLIMAIR GmbH	www.wesco.ch www.sudclimatair.ch www.climair.ch
DK	Øland A/S	www.oeland.dk
EE	BVT Partners	www.bvtpartners.ee
FR	ATIB	www.atib.fr
HR	Microclima	www.microclima.hr
HU	AIRVENT Légtechnikai Zrt. Gevent Magyarorszáig Kft. Merkapt	www.airvent.hu www.gevent.hu www.merkapt.hu
IE	Lindab	www.lindab.ie
IR	Fantech Ventilation Ltd	www.fantech.ie
IS	Blikk & Tækniþjónustan ehf Hitataekni ehf	www.bogt.is www.hitataekni.is
IT	ICARIA	www.icaria.srl
NL	Ventilair group DECIPOL-Vortvent CLIMA DIRECT BV	www.ventilairgroup.com www.vortvent.nl www.climadirect.com
NO	Ventilution AS Ventistål AS Thermo Control AS	www.ventilution.no www.ventistal.no www.thermocontrol.no
PL	Ventia Sp. z o.o.	www.ventia.pl
SE	Nordisk Ventilator AB	www.nordiskventilator.se
SI	Agregat d.o.o	www.agregat.si
SK	TZB produkt, s.r.o.	www.tzbprodukt.sk
UA	TD VECON LLC	www.vecon.ua